

1 PROJECT DESCRIPTION, LOCATION, AND ENVIRONMENTAL SETTING**1.1 Project Objectives**

The fundamental purpose of the Campo Wind Project with Boulder Brush Facilities (Project) is to generate and deliver to the grid renewable wind energy to meet the demands of consumers. Terra-Gen Development Company LLC (Developer) proposes to develop, finance, and construct the wind turbines and other Project components on the Campo Band of Diegueño Mission Indians (Tribe) Reservation (Reservation) in southeastern San Diego County (Campo Wind Facilities). The Developer would also own, operate, maintain and ultimately decommission the Campo Wind facilities. Boulder Brush LLC (Boulder Brush Developer) proposes to develop, finance, and construct supporting transmission and interconnection infrastructure on private lands in southeastern San Diego County (Boulder Brush Facilities). The Boulder Brush Developer would also own, operate, maintain, and, ultimately decommission the Boulder Brush Facilities, except for the switchyard and incoming/outgoing connection lines components that would be owned and operated by San Diego Gas & Electric Company (SDG&E).

Specific objectives for the Project are as follows:

1. Develop approximately 252 megawatts (MW) of renewable wind energy that can offset the need for additional energy production from fossil fuels and assist the state in meeting its air quality goals and reduce greenhouse gas (GHG) emissions in conformance with Assembly Bill 32 and Senate Bill 32.
2. Develop a wind energy project that can meet the criteria to achieve the maximum federal tax credit requiring placement into operation by December 31, 2020, which is intended to decrease the cost of renewable energy generation and delivery, promote the diversity of energy supply, and decrease dependence of the United States on foreign energy supplies.
3. Assist in achieving the state's goal of delivering 100% zero carbon energy by 2045.
4. Develop a wind energy facility as near as possible to existing transmission infrastructure.
5. Develop a wind energy facility within the Reservation, enhancing their economy by creating short- and long-term employment opportunities and providing long-term revenue.
6. Support an economically feasible wind energy project that would be developed through commercially available financing.
7. Support displacement of approximately 58,000 tons of carbon dioxide (CO₂, a GHG) emissions per year that would otherwise be required to generate the same amount of electricity as generated by the Project.

1.2 Project Description

For purposes of this Environmental Impact Report (EIR), the Project is referred to as the “Campo Wind Project with Boulder Brush Facilities,” or “Project” for short. The County of San Diego (County) is the Lead Agency for the Project under the California Environmental Quality Act (CEQA). The Bureau of Indian Affairs (BIA) is the Lead Agency for the Project under the National Environmental Policy Act (NEPA), and has prepared an Environmental Impact Statement (EIS) for the Project (BIA 2019).

The Project would consist of the Campo Wind Facilities that would be located on land leased from the Tribe within the Reservation Boundary, and the Boulder Brush Facilities that would be located on adjacent land to the northeast of the Reservation leased from a private landowner within the Boulder Brush Boundary. Implementation of the Campo Wind Facilities requires BIA approval of a 25-year lease (with the possibility of a 13-year extension) of land within the Reservation Boundary between the Tribe and the Developer (Campo Lease). Approval of the Campo Lease would allow Terra-Gen Development Company LLC to develop, construct, operate, maintain, and ultimately decommission the Campo Wind Facilities on leased land within the Reservation Boundary. Approval of the Campo Lease will authorize the Tribe’s lease of trust land consistent with federal laws and regulations governing the leasing of tribal trust lands and the federal trust responsibility to tribes. Collectively, the land within both the Reservation Boundary and Boulder Brush Boundary comprise the Project Area (see Figure 1-1, Project Location, and Figure 1-2, Project Area). Throughout this document, the term “On-Reservation” refers to anything within the Reservation Boundary, whereas the term “Off-Reservation” refers to anything outside of the Reservation Boundary.

The Campo Wind Facilities, which would consist of 60 wind turbines and associated infrastructure, would be located within a corridor of approximately 2,200 acres of land (Campo Corridor) within the approximately 16,000-acre Reservation Boundary. The Boulder Brush Facilities, which would consist of a portion of the Project generation transmission line and related facilities to connect energy generated by the Project to the existing San Diego Gas & Electric Company (SDG&E) Sunrise Powerlink, would be located within a corridor of approximately 320 acres of land (Boulder Brush Corridor) within the approximately 2,000-acre Boulder Brush Boundary. These Private Lease lands are under the land use and permitting jurisdiction of the County. Collectively, the Campo Corridor and the Boulder Brush Corridor compose the approximately 2,520-acre Project Site. Project disturbances associated with the construction of the Campo Wind Facilities within the Campo Corridor are expected to be approximately 800 acres, whereas Project disturbances associated with the construction of the Boulder Brush Facilities within the Boulder Brush Corridor are expected to be approximately 130 acres.

The Project as a whole would consist of the construction, operation, maintenance, and ultimately the decommissioning of a renewable wind energy generation project consisting of 60 wind turbines, three permanent meteorological (MET) towers, six temporary MET towers, a temporary concrete batch plant for use during construction, a temporary equipment staging and parking area for use during construction, an operations and maintenance (O&M) facility, water collection and septic systems, access roads, an electrical collection and communications system (ECCS), an approximately 8.5-mile-long generation transmission (gen-tie) line, a collector substation, a high-voltage substation, and a switchyard to interconnect the Project to the existing SDG&E Sunrise Powerlink (see Figure 1-3, Project Site Plan). The Project would operate for more than 30 years, after which it would be decommissioned, except for the SDG&E-owned and operated switchyard and connection lines to Sunrise Powerlink, which would not be decommissioned. The details regarding the Project components and construction and decommissioning thereof are provided herein (for details, see Section 1.2.1).

1.2.1 Component Parts of the Project

A summary description of the Project components is provided in this section. The Boulder Brush Facilities are discussed in Section A, and the Campo Wind Facilities are discussed in corresponding Sections B through K, as follows:

- A. Boulder Brush Facilities
- B. Wind Turbines
- C. Access Roads
- D. Electrical Collection and Communications System
- E. Collector Substation
- F. O&M Facility
- G. Meteorological Towers
- H. Water Collection and Septic Systems
- I. Temporary Concrete Batch Plant for use during Construction
- J. Temporary Staging and Parking Areas for use during Construction
- K. On-Reservation Gen-Tie Line

As noted above and explained further below, the County has no permitting or land use jurisdiction over the Campo Wind Facilities.

A. Boulder Brush Facilities

The Boulder Brush Facilities include the following components:

1. Off-Reservation gen-tie line
2. High-voltage substation
3. 500-kilovolt (kV) switchyard and connection to the existing SDG&E Sunrise Powerlink
4. Access roads
5. Three 10,000-gallon water tanks
6. Defensible space (fuel modification zones)

These components are shown in Figure 1-4 and Figure 1-4A through Figure 1-4G, Boulder Brush Site Plan.

1) Off-Reservation Gen-Tie Line

Approximately 3.5 miles of the approximately 8.5-mile-long, overhead 230 kV gen-tie line that would transmit the electricity from the Campo Wind Facilities to the Off-Reservation high-voltage substation and switchyard would be constructed within the Boulder Brush Corridor on private land. This segment of the gen-tie line would require approximately 32 steel pole structures that, in addition to the transmission wires, would accommodate a fiber-optic ground wire attachment for lightning protection and internal communications. The height of the steel pole structures would vary by location, up to a maximum height of 150 feet (see Figure 1-5, Transmission Line Pole Structure Example).

2) High-Voltage Substation

A high-voltage substation would be constructed within the Boulder Brush Corridor and located adjacent to the proposed 500 kV switchyard at the northern portion of the privately owned parcels. This high-voltage substation would receive the electric energy transmitted from the Campo Wind Facilities along the 230 kV gen-tie line and convert it up to the 500 kV voltage via a 230 kV to 500 kV transformer before transmitting it onward to the adjacent switchyard.

The high-voltage substation equipment would include transformers that would be connected through circuit breakers to a jumper link located within the fenced boundary of the high-voltage substation to deliver power to the point of interconnection at the adjacent switchyard. Figure 1-6, Typical Substation Design, shows a typical layout design for a substation. The high-voltage substation would include a control ~~house~~-shelter and a parking area for utility vehicles. The high-voltage substation would generally be an unstaffed facility, except in cases of maintenance and repair activities.

The high-voltage substation would require a fenced-in footprint of approximately 220 feet by 320 feet (1.6 acres). An additional approximately 1-acre area of disturbance would be required for site grading and clearing around the perimeter of the fenced-in footprint. The total disturbed area associated with the high-voltage substation would be approximately 2.5 acres. The cleared area surrounding the high-voltage substation and the area inside the high-voltage substation fence would be covered with gravel. An 8-foot-tall security fence consisting of 6-foot-tall chain-link fencing topped with an additional 2 feet of security wire would be installed around the perimeter of the high-voltage substation site. The high-voltage substation would include a contiguous fuel modification zone 50 feet outside the perimeter fence (approximately 100 feet from the electrical components). The high-voltage substation pad area would be free of vegetation around all electrical equipment. The high-voltage substation fence and the gravel area within the fence would be grounded.

Most high-voltage substation equipment would feature a low-reflectivity finish to minimize glare. Dull-colored insulators would be used to minimize visibility. Outdoor nighttime lighting at the high-voltage substation would be kept to the minimum required for security and safety, and all lighting would be hooded, directed downward, and turned off when not required. Some of the perimeter lighting would remain on all night for safety purposes, though shielded and directed towards accesses or signs.

The high-voltage substation would allow for the receiving and stepping up of electric energy from 230 kV to 500 kV for the proposed Torrey Wind Project, a separate wind energy project proposed on private lands under County jurisdiction. The Torrey Wind Project would also be located within the area identified as the Boulder Brush Boundary. If both the Project and the Torrey Wind Project are approved, using the high-voltage substation for both projects would reduce the overall environmental footprint of the two wind projects by constructing a single, shared facility. If only the Project is approved, the high-voltage substation would be constructed to serve only the Project. Similarly, if only the Torrey Wind Project is approved, the high-voltage substation would be built to serve only the Torrey Wind Project.

3) 500 kV Switchyard and Connection to the Existing SDG&E Sunrise Powerlink

A new 500 kV switchyard would be constructed on a stand-alone parcel within the Boulder Brush Corridor adjacent to the proposed high-voltage substation. Upon completion, this approximately 16-acre parcel and the switchyard would be transferred to SDG&E, who would then own, operate, and maintain the switchyard. The switchyard would interconnect the Project to the existing Sunrise Powerlink by a ring bus design with three 500 kV breakers, a control ~~houses~~shelter, and a fenced-in graveled area. The connection to the Sunrise Powerlink would be made through incoming and outgoing connection lines, to be constructed by SDG&E, that would effectively route the power through the ring bus. The Project's point of interconnection would be at an open position on that same bus within the switchyard. Figure 1-7, Switchyard Layout, shows a typical layout design for the switchyard.

The switchyard would require a fenced-in footprint of approximately 400 feet by 750 feet (6.9 acres). An additional approximately 9.5 acres of disturbed area would be required for the access road, incoming and outgoing connection lines, 0.6-acre earthen bottom detention basin~~retention pond~~, a 50-foot fuel modification zone around the perimeter of the switchyard (approximately 100 feet from the electrical components), and site grading and clearing. Up to 30-foot-tall fencing would be installed around the perimeter of the switchyard, in accordance with SDG&E requirements. Therefore, the total disturbance area for the switchyard and incoming and outgoing connection lines would be approximately 16 acres.

An approximately 40-foot gap between the perimeter fence on the eastern side of the high-voltage substation and the perimeter fence on the western side of the switchyard would contain a transmission line pole structure supporting an overhead 500 kV line that would connect the high-voltage substation to the switchyard. The transmission line pole structure between the switchyard and the high-voltage substation and the transmission line on the switchyard side of the line between the switchyard and high-voltage substation would be owned and maintained by SDG&E.

The incoming and outgoing connection lines (approximately 1,000 feet in length) and the associated pole structures and foundations that would connect the switchyard to the Sunrise Powerlink would be constructed, owned, and operated by SDG&E and would not be included in the County's Major Use Permit (MUP) (see Figure 1-8, SDG&E Connection Schematic). Impacts associated with these components as well as their construction, including access roads, foundation pads and pull sites are accounted for throughout this EIR. Because the incoming and outgoing connection lines would be constructed by SDG&E, they are subject to the jurisdiction of the California Public Utilities Commission for both construction and operation. After the switchyard is constructed and transferred to SDG&E, its operation and maintenance would also be under California Public Utilities Commission jurisdiction. The operation of the remaining Boulder Brush Facilities (gen-tie line, access road, and high-voltage substation) would remain subject to the County's jurisdiction.

As with the high-voltage substation, the switchyard would also provide interconnection for the proposed Torrey Wind project, a separate project proposed within the Boulder Brush Boundary. If both the Torrey Wind project and the Project are approved, using the switchyard for both projects would reduce the overall environmental footprint of the two wind projects by constructing a single, shared facility. If only the Project is approved, the switchyard would be constructed to serve only the Project. Similarly, if only the Torrey Wind project is approved, the switchyard would be built to serve only the Torrey Wind project.

4) Access Roads

On-Site Roadway Improvements

Primary access to the Boulder Brush Facilities would be provided from Interstate (I) 8, with local access provided via Ribbonwood Road (see Figure 1-9A, Project Access Roads). An approximately 3.5-mile-long and up to 30-foot-wide new paved access road from the Boulder Brush Facilities site entrance to the high-voltage substation and switchyard would be constructed. Approximately 2.6 miles of this paved access road would run parallel and adjacent to a portion of the proposed Off-Reservation gen-tie line and would also serve as access to approximately 24 Off-Reservation gen-tie line pole structures. New permanent access roads would incorporate applicable federal and local standards regarding internal road design and circulation, particularly those provisions related to emergency vehicle access. This new paved access road would be a minimum of 20 feet in width and maximum of 30 feet in width, with 20 feet of fuel modification on each side of the road. To the extent feasible, the road alignment follows existing disturbed areas.

The approximately eight remaining Off-Reservation gen-tie line pole structures would be accessed by approximately 4 miles of improved decomposed granite roads, of which 2.8 miles would be located in areas of prior disturbance. The decomposed granite roads would be constructed or widened to a width of 16 feet. An approximately 20-foot-wide fuel modification zone would be maintained on either side of the on-site unpaved access roads for the Boulder Brush Facilities. All on-site roads would be privately maintained.

All unpaved access roads would consist of compacted native material and may also have approximately 4–6 inches of aggregate and/or geosynthetic material to provide the soil strength needed for construction. The temporary disturbance areas outside the final roadway width would be graded and compacted for use during construction and then decompacted and stabilized at the conclusion of construction. Roads would be constructed or upgraded in accordance with industry standards. Bulldozers and graders would be used to build and widen roads, and a water truck would be used for road compaction and dust control. Access roads would be maintained, as needed, during operations. SDG&E would have use of the access roads after construction is complete for the purpose of operations and maintenance of their facilities.

Prior to construction of roadway improvements, roadway improvement boundaries would be marked by stakes every 200 feet in accordance with industry standards to delineate the extent of allowed grading limits. Additionally, all on-site construction workers performing ground-disturbance activities would be equipped with GPS units that would clearly delineate the limits of grading. This construction design feature is identified as Project Design Feature **(PDF) CON-1**, which would be enforced as a Condition of Approval to the MUP and provided on the grading plan notes.

Prior to start of construction, a Traffic Control Plan would be prepared for the Project to address transportation activities, such as the delivery of turbine components, main assembly cranes, and other large pieces of equipment, to reduce impacts to off-site traffic flow. The Traffic Control Plan would also identify the requirements for road design, construction, and O&M. CEPA and the County would be responsible for the review of the Traffic Control Plan.

Off-Site Roadway Improvements

An approximately 1-mile off-site segment of Ribbonwood Road from the Opalocka Road/Ribbonwood Road intersection to the Boulder Brush Facilities site entrance off Ribbonwood Road would be improved. This existing, unpaved roadway segment ranges from 12 feet wide to 40 feet wide and would be widened up to 30 feet and paved. A 20-foot-wide fuel modification on either side of this road would be provided where feasible. Subject to County approval, the width of the fuel modification zone along either side of the portion of the access road outside of the Boulder Brush Boundary (between Opalocka Road and the Boulder Brush Boundary) would depend upon the final width of the improved, paved access road and its placement relative to the access easements that it will reside within. This paved road would link to the proposed on-site up to 30-foot-wide paved access road providing access to the Boulder Brush Facilities including the high-voltage substation and switchyard (see Figure 1-9B, Boulder Brush Access Roads).

Prior to construction of off-site roadway improvements, improvement boundaries would be marked by stakes every 200 feet in accordance with industry standards to delineate the extent of allowed grading limits. Additionally, all on-site construction workers performing ground disturbance activities would be equipped with GPS units that would clearly delineate the limits of grading. This construction design feature is identified as **PDF-CON-2**, which would be enforced as a Condition of Approval to the MUP and provided on the grading plan notes.

5) Water Tanks

Three 10,000-gallon water tanks dedicated for firefighting purposes would be installed near the high-voltage substation, in a location subject to County approval. The three water tanks would be sourced by Jacumba Community Services District (JCS D) or Padre Dam Municipal Water District (PDMWD) with non-potable water.

6) Defensible Space (Fuel Modification Zones)

Fire protection measures are defined in County Code Regulatory Ordinance, Title 9, Division 6, Chapter 1, County Fire Code. The regulations identify access road requirements and fuel modification zone requirements.

County Code, Section 96.1.503.1.1, specifies that “approved fire apparatus access roads shall be provided for every facility, building, or portion of building hereafter constructed or moved into or within the jurisdiction. The fire apparatus access road shall comply with the requirements of this section and shall extend within 150 feet of all portions of the facility and all portions of the exterior walls of the first story of the building as measured by an approved route around the exterior of the building or facility.” Exceptions are as follows:

Exceptions: The fire code official may increase the 150-foot minimum where:

1. Fire apparatus access roads cannot be installed because of topography, waterways, nonnegotiable grades or other similar conditions, and an approved alternative means of fire protection is provided.
2. There are no more than two Group R-3 or Group U occupancies.

County Code, Section 96.1.202, defines a fuel modification zone as a strip of land where combustible vegetation has been thinned or modified or both and partially or totally replaced with fire-resistant and/or irrigated plants to provide an acceptable level of risk from vegetation fires. Fuel modification reduces the radiant and convective heat on a structure and provides valuable defensible space for firefighters to make an effective stand against an approaching fire front.

Permanent access roads would be constructed to provide access to the high-voltage substation and switchyard. County Code, Section 96.1.4907.2.1, specifies fuel modification of combustible vegetation from sides of roadways. Details regarding the extent of defensible space and fuel modification zones will be determined prior to final design with the input of relevant fire authorities. The Fire Authority Having Jurisdiction may require a property owner to modify combustible vegetation in the area within 20 feet from each side of the driveway or a public or private road adjacent to the property to establish a fuel modification zone. The nearest fire station, California Department of Forestry and Fire Protection (CAL FIRE) Boulevard, is located just south of I-8, off of Ribbonwood Road.

B. Wind Turbines

The Project would include up to 60 wind turbines within the Campo Corridor on the Reservation. A total of 76 wind turbine sites within the Reservation are shown in Figure 1-3 and have been analyzed in this EIR; however, only 60 turbines would be constructed in accordance with the Campo Lease. Further, as a result of Federal Aviation Administration review, four of the 76 identified wind turbine sites would not be utilized. These four wind turbine sites are located in the northwestern corner of the Reservation (Refer to Figure 1-3). The 60 wind turbines would be arranged in accordance with applicable industry siting recommendations for optimum energy production and minimal land disturbance. Since wind turbine technology is continually improving, and the cost and availability of specific types of turbines vary from year to year, final turbine

specifications are not available; however, the following dimensions are representative for turbines that would be installed:

- Sixty wind turbines, rated up to 4.2 MW in nameplate capacity per turbine
- Multiple tubular steel tower sections forming the towers
- Rotor diameter – up to approximately 460 feet (approximately 230-foot-long blades)
- Foundation pedestal – approximately 20 feet in diameter and 6 inches above grade
- Hub height – up to approximately 374 feet
- Total height of turbine (highest point) – up to approximately 586 feet

Wind turbines would consist of three main physical components that are manufactured off site and assembled and erected during construction within the Reservation: the tower (composed of multiple sections), the nacelle (the component of the wind turbine that houses the main mechanical components), and the rotor (which consists of three blades mounted on a hub) (see Figure 1-10, Typical Wind Turbine Specifications). All proposed turbines would be three-bladed, upwind, horizontal-axis wind turbines. Each turbine would be mounted on a concrete pedestal (approximately 20 feet in diameter and 6 inches above grade) supported by a permanent, below-grade concrete foundation (approximately 70 to 80 feet in diameter and 10 feet deep). Each turbine would have a rotor and nacelle mounted on top of its tubular tower.

Shadow flicker (a term used to describe the flickering of shadows that are cast by a wind turbine's rotating blades when the sun is behind them), is discussed and analyzed in Section 2.1, Aesthetics, of this EIR. Consistent with the EIS, the following PDFs would be implemented as part of Campo Wind Facilities operation:

PDF-AE-1 Shadow Flicker (On-Reservation). The Developer will coordinate with the relevant tribe to assess shadow flicker complaints made within one year from the initial operations date of the Project by the resident of any existing (existing as of the date of ROD approval) On-Reservations receptor located within a distance of 15 x Rotor Diameter (i.e. approximately 6,750 feet) of a Project turbine. This assessment would include possible remedies that the Developer may implement depending upon the level of shadow flicker impacts occurring at the On-Reservations receptor, including financial assistance for the installation of screening vegetation or window coverings. Requests for assistance can be made through a Project hotline to be established by the Developer and published to the Developer's website.

PDF-AE-2 Shadow Flicker (Off-Reservation). While BIA lacks jurisdiction to impose Project conditions implemented Off-Reservations, the Developer will coordinate with the resident of any existing (existing as of the date of ROD approval) Off-Reservations receptor located within a distance of 15 x Rotor Diameter (i.e. approximately 6,750 feet) of a Project turbine to assess their shadow flicker complaints made within one year from the initial operations date of the Project. This assessment would include possible remedies that the Developer may implement depending upon the level of shadow flicker impacts occurring at the Off-Reservations receptor, including financial assistance for the installation of screening vegetation or window coverings. Requests for assistance can be made through a Project hotline to be established by the Developer and published to the Developer's website.

Turbine Tower

Each wind turbine tower would be a tubular conical steel structure. The bolting flange at the base of the tower would extend out from the tower wall approximately 0.5 feet, resulting in an outer diameter of approximately 20 feet for the bolting flange at the tower base. The tower would have an access door at its base and an internal ladder to the top of the tower at the nacelle. A service platform at the top of each tower section would allow for access to the tower connecting bolts for routine inspection. The tower would be equipped with interior lighting and a safety guide cable alongside the ladder. No ladders would be located on the outside of the structures. Towers would be painted off-white for aviation visibility and to provide corrosion protection. All turbine tower access doors would be locked to limit public access, with no fencing.

Nacelle

The nacelle is the component of the wind turbine that houses the main mechanical components, which consist of the drive train, gearbox, and generator. The nacelle would be equipped with an anemometer and a wind vane that signals wind speed and direction information to an electronic controller. An electric motor would rotate the nacelle and rotor to keep the turbine pointed into the wind to maximize energy capture. An enclosed, steel-reinforced fiberglass shell would house the nacelle to protect internal machinery from the elements.

Nacelle functions include yawing the nacelle into the wind and pitching the blades to either capture wind energy to make the rotor turn or stall the blades to stop the rotor when necessary. Independent electric drives in the rotor hub would rotate the angle of each blade according to wind conditions, which would enable the turbine to operate efficiently at varying wind speeds and reduce deterioration of the drive train in higher-wind conditions. Wind turbine rotors would be designed with an automatic braking mechanism that consists of electric-drive blade pitch systems on each blade of the

wind turbine. Under normal operating conditions, braking is accomplished by feathering the blades out of the wind. Single feathered rotor blades are designed to slow the rotor, and each rotor blade would have its own back-up to provide power to the electric drive in the event of a grid line loss.

Wind turbines can operate 24 hours a day, 7 days a week. Blades typically begin to rotate and turbines begin to generate power in winds as low as 6.7 miles per hour, referred to as the cut-in speed, and are designed to operate in wind speeds up to approximately 56 miles per hour, referred to as the cut-out speed. At wind speeds faster than 56 miles per hour, blades rotate parallel to the wind (blades are fully feathered) and the wind turbine stops producing electricity. This braking system is linked to the wind turbine control system used to prevent over-speeding of the rotor. Each wind turbine would also be equipped with a mechanical brake located at the output shaft of the gearbox. This brake is only applied to prevent rotation of the machinery for certain service activities. Turbines can withstand sustained wind speeds of more than approximately 100 miles per hour.

Lighting

The Developer would implement a lighting plan in accordance with current Federal Aviation Administration (FAA) standards. An estimated 60% to 65% of the turbines would be designated for lighting with medium-intensity, dual red or white synchronously flashing lights for nighttime use and daytime use, if needed. These lights would have the minimum number of flashes per minute and the briefest flash duration allowable per current FAA standards to prevent congregation of night migrating birds (Evans et al. 2007). All pilot warning lights would light synchronously. The number of wind turbines that would be lit would be minimized, and determined by the FAA, with a maximum separation gap between lights of less than 0.5 miles (Larwood 2005). A low-voltage, shielded light on a motion sensor would be installed at the entrance door to each wind turbine at the base of the turbine tower for security purposes. Lights on the components other than turbines (e.g., O&M facility, collector substation) would be motion sensitive rather than steady burning; lights would be installed in a “high-mounted light” manner and directed downward to minimize spill light.

C. Access Roads

Where feasible, the existing network of On-Reservation permanent roads would be used to access the Campo Wind Facilities during construction. In addition to the existing roads, additional roads would be constructed on the Reservation to provide access and circulation (see Figure 1-9A, Project Access Roads). Access road layout would involve approximately 15 miles of new On-Reservation roads. All of these roads are anticipated to be used for access to the Campo Wind Facilities over the life of the Project. Existing roads would be improved to accommodate construction equipment delivery and access. It is anticipated that approximately 15 miles of existing roads would need to be temporarily widened up to 40 feet during construction and reduced

to approximately 24 feet after construction. Likewise, the width of the new roads would be up to 40 feet during construction and reduced to approximately 24 feet after construction. Access roads to the gen-tie line pole structures would be approximately 16 feet.

Upon completion of construction, all new access roads more than 24 feet wide would be reduced to approximately 24 feet wide, and the edges of the existing roads would be restored and the existing widths would be returned to pre-construction widths. Along either side of new access roads, a 6-foot-wide vegetation management area would be maintained. Roads would be designed to prevent soil erosion and to maintain existing surface water runoff patterns. Wherever practicable, roads would be designed with a maximum grade of 10%, but in certain instances, grades may need to be steeper.

On-Reservation access roads would be constructed of native soils with decomposed granite and gravel, or similar suitable materials, to provide access in nearly all weather conditions. Roads would be constructed or upgraded in accordance with industry standards. Bulldozers and graders would be used to build and widen roads, and a water truck would be used for road compaction and dust control. Compaction requirements to build embankments for roads and compaction equipment would be determined by the geotechnical engineer of record for the Project.

Access roads would be maintained during operations to prevent off-road detours due to ruts, mud holes, or other deterrents. Roads would be maintained as needed; it is anticipated that maintenance would occur twice per year, but more frequent maintenance would be performed if needed.

D. Electrical Collection and Communications System

The turbines would be connected to the collector substation through a 34.5 kV underground ECCS within the Reservation. Depending on the turbine model selected, the electric energy produced by each wind turbine would be conducted through cables to either a transformer located inside the nacelle or through cables running down the inside of the wind turbine tower, through an underground conduit, to a pad-mounted transformer that would sit approximately 10 feet from the base of the wind turbine tower on a separate foundation or “pad.” The pad-mounted transformer would be approximately 6.5 feet tall by 7 feet wide by 8.5 feet deep. The turbine transformer would transform power from the turbine output voltage of approximately 600–1,000 volts up to 34.5 kV. This boost is necessary because the low-voltage power generated by the wind turbines is not suitable for distribution within the Campo Corridor, since it would require larger underground electrical collection cables and generate higher power losses. The 34.5 kV side of the transformer would be connected to a system of insulated and shielded underground cables, referred to as the underground ECCS. Generated electricity would move through the underground ECCS to the collector substation on the Reservation.

Approximately 28 miles of underground ECCS cable would be installed in temporary trenches in order to connect each wind turbine to the collector substation. There would be three cable conductors, one grounding wire, and one fiber optic cable installed per trench approximately 4 feet below grade. A red warning tape stating “Buried Cable” or similar would also be placed in the trench, above the cables and approximately 1 foot below grade. The underground ECCS would be routed to minimize the overall cable length required for the Campo Wind Facilities and to lessen the temporary impacts associated with the trenching. For example, cables would be routed in parallel and/or adjacent to access roads to the extent feasible. However, in some cases, trenches would run overland from the end of one turbine string to an adjacent string. Each trench would be approximately 2–4 feet wide and 4 feet deep. An additional, approximately 24 feet of temporary disturbance alongside the trench would be required to account for trenching equipment and temporary placement of excavation. Depending on terrain, an approximately 40-foot-wide area may be required to install portions of the underground ECCS cables using a combination of trenching, open excavation, and directional boring. In addition, certain areas may not be feasible for trenching due to solid rock, large boulders, or subsurface resources. In these instances, a temporary worksite 15 feet to 20 feet wide may be required to enable construction of overhead ECCS circuits. These overhead circuits would be supported on steel/concrete/wood monopoles up to 60 feet in height that would be spaced approximately 450 feet apart. Junction boxes for access to underground cables for inspection, maintenance, and repair would be installed at approximately 0.2-mile intervals. Once installed, the disturbed areas would be revegetated with a native seed mix.

E. Collector Substation

The underground ECCS would be routed to the proposed collector substation centrally located within the Campo Corridor on the Reservation. This collector substation would be located in a yard approximately 1 acre in size. Transformer and switching equipment within the collector substation would be up to approximately 25 feet tall. Lighting at the collector substation would be provided for safety and security purposes. The collector substation would be enclosed by an 8-foot-tall chain-link fence with locked gates. The collector substation would contain the main transformer for the Project and circuit breakers for each of the underground ECCS circuits. Electricity at 34.5 kV from the wind turbines would flow into the circuit breakers, be transformed by the transformer to 230 kV, and would then be conducted for delivery via the gen-tie line. Two 10,000-gallon water tanks dedicated for firefighting purposes would be installed within the collector substation yard.

All collector substation monitoring and control functions would be performed remotely. Warning signs would be posted and entry to the substation would be restricted to authorized personnel.

F. Operation and Maintenance Facility

An O&M facility would be located within one of the two temporary central staging areas within the Campo Corridor on the Reservation (see Figure 1-3, Project Site Plan). The facility would include a 1.5-acre parking and equipment storage area and a pre-engineered structure. The O&M facility would contain monitoring and control equipment. Amenities at the O&M facility would include a main building with offices, spare parts storage, restrooms, a shop area, outdoor parking facilities, a turnaround area for larger vehicles, outdoor lighting, and gated access with partial or full perimeter fencing. In addition, two 10,000-gallon water tanks dedicated for firefighting purposes would be installed at the O&M facility. Permanent outdoor nighttime lighting for operations would be kept to the minimum required for security and safety, and all lighting would be hooded, directed downward, and turned off when not required. Security fencing (6 feet tall) would be installed around the perimeter of the O&M facility. Downcast lighting would be installed around the perimeter of the facility for safety and security and would be motion sensitive rather than steady burning. In addition, an electrical heating, ventilation, air conditioning system, and a fire suppression system would be installed for the O&M facility for the permanent O&M staff who would operate from this facility. It is anticipated that on-site groundwater sourced from an existing, nearby groundwater well would be used for the Project's operation, otherwise water would be trucked in from JCSD or PDMWD. The O&M facility would require a potable water source for employee uses for the restrooms (regular and compliant with the Americans with Disabilities Act), a kitchen sink, and emergency wash station. A parking area for O&M staff and a staging area would also be located within the fenced, access-controlled O&M facility site. The facility would normally be staffed on a daily basis, and security personnel would patrol the facility. A septic system is proposed to provide sewer service to the O&M facility during operation. The septic system would be sufficient to provide service for employees and would include a leach field located adjacent the O&M facility, where traffic would not occur. Estimated water use and wastewater generation would be approximately 210 gallons per day (gpd) each.

G. Meteorological Towers

Up to three permanent MET towers would be constructed within the Campo Corridor on the Reservation to monitor and record weather conditions and to perform power performance testing of the wind turbines. The height of these MET towers would equal the hub height of the wind turbines to be installed. They would be un-guyed, self-supporting, lattice structures mounted on an approximately 26-foot by 26-foot concrete foundation. The towers would be enclosed within an approximately 50-foot by 50-foot perimeter by an 8-foot-tall chain-link fence with locked gates. Lighting for the MET towers would consist of marker lighting pursuant to FAA requirements, and would employ strobed, minimum-intensity lights as recommended by the U.S. Fish and Wildlife Service (USFWS 2016).

Up to six, temporary MET towers would also be erected within the Campo Corridor on the Reservation as part of the Project's wind turbine power curve testing campaign that would occur prior to commercial operations. These temporary MET towers would be constructed atop targeted wind turbine locations (after site grading but prior to the erection of those wind turbines) to collect turbine site-specific wind data that would be used to calibrate these locations prior to performing power curve testing. The height of these MET towers would also equal the hub height of the wind turbines to be installed and would be equipped with applicable FAA-compliant marking and lighting for aviation safety. The temporary MET towers would be guyed-lattice towers constructed atop a relatively smaller, temporary concrete foundation. These MET towers would be removed prior to the erection of the turbines and upon collecting sufficient, site-specific wind data.

Each MET tower would have instrument booms and cabling for all meteorological instruments, ladders, FAA lighting, and other instruments that may be required. The permanent MET towers would initially be supplied power by a battery/solar panel combination installed at the base of each tower. Once the Project has reached commercial operation, the permanent MET towers would be supplied power and fiber optic cabling from the nearest turbine so that the Supervisory Control and Data Acquisition (SCADA) system could collect the data from the tower. A road would be provided to each permanent MET tower from the nearest Project road access point. Meteorological instruments would be mounted on both the permanent and temporary MET towers at various heights, up to the top of each tower.

H. Water Collection and Septic Systems

As previously stated, the O&M facility would have an operational water demand of approximately 210 gpd for the sanitary functions associated with personnel. Water sources during operation would consist of connection to existing On-Reservation facilities in the vicinity of the proposed O&M facility, generally consistent with the connection and sizing necessary for a single-family home.

Consistent with the EIS, the following PDF would be implemented as part of Campo Wind Facilities operation:

PDF-HY-1 Groundwater Monitoring: Campo Environmental Protection Agency (CEPA) will monitor the depth to groundwater in wells located between existing On-Reservation production wells anticipated to be a source of groundwater supply for Project construction and other nearby On-Reservation production wells. A groundwater level drawdown threshold for On-Reservation monitoring wells should be established to ensure that declines in groundwater levels in On-Reservation wells remain at less than 20 feet resultant from On-Reservation pumping for Project construction. Groundwater level monitoring should be conducted at least weekly during Project construction and do not interfere with

individual and Public Water System (PWS) wells that provide drinking water to residents and others. Should the groundwater drawdown threshold be exceeded, CEPA will require the cessation of on-site pumping for Project construction, from such production wells as is necessary, until groundwater levels in the monitoring wells rise above the threshold.

Additionally, the following PDF would be implemented as part of the Boulder Brush Facilities to ensure that water levels in the aquifers accessed by off-site water sources would be avoided.

PDF-HY-2 Implementation of GMMP for JCSD: To ensure non-potable water purchased from the Jacumba Community Services District (JCSD) does not result in impacts to the aquifers accessed by JCSD's non-potable water production wells (Well 6, Highland Center Well, and Park Well), the Boulder Brush Developer will implement the Groundwater Mitigation Monitoring and Mitigation Plans (GMMPs) for the Flat Creek and Boundary Creek Watersheds.

I. Temporary Concrete Batch Plant for Use during Construction

A temporary concrete batch plant would be established within the Campo Corridor on the Reservation to mix the necessary concrete for foundations of the turbines, MET towers, substations, transmission poles, and the O&M facility. The concrete batch plant would occupy an area of approximately 400 feet by 400 feet, or 3.7 acres, within the Campo Corridor. The concrete batch plant would consist of a mixing plant, areas for aggregate and sand stockpiles, driveways, truck load-out area, and turnaround(s). The concrete batch plant would include cement storage silos, water and mixture tanks, aggregate hoppers, conveyors, and augers to deliver different materials to the mixing plant. The batch plant would be located just off an access road.

J. Temporary Staging and Parking Areas for Use during Construction

Temporary staging areas have two uses: as central staging and as turbine staging during the construction phase of the Project. Two central temporary staging areas within the Campo Corridor on the Reservation of approximately 20 acres total would be established for construction-management facilities, materials and equipment storage, and worker parking. Vehicle parking would be clearly marked and limited to areas away from sensitive habitat. Upon completion of construction, the O&M facility would be located within one of the central staging area footprints. In addition to the temporary central staging areas, each turbine would require a temporary staging area at the turbine location for the assembly of the turbine components and to erect each turbine. Each temporary staging area for a turbine would be approximately 100 feet by 200 feet, plus clearing for blades.

K. On-Reservation Gen-Tie Line

The Project includes an approximately 8.5-mile 230 kV gen-tie line, originating at the collector substation and terminating at the high-voltage substation. An approximately 5-mile-long segment of the gen-tie line, including approximately 42 support poles, fiber-optic ground wire attachment for lightning protection and internal communications, would be located within the Campo Corridor on the Reservation as part of the Campo Wind Facilities. This segment (i.e., the On-Reservation gen-tie line) would be constructed from the collector substation to the Reservation Boundary and includes the crossing of I-8. The remaining approximately 3.5 miles of gen-tie line from the Reservation Boundary to the Off-Reservation high-voltage substation is included in the Boulder Brush Facilities and discussed above. The height of the steel poles would vary by location up to a maximum height of 150 feet.

1.2.2 Construction

Construction of the Project is anticipated to occur over approximately 14 months. Some portions of Project construction would likely take place simultaneously at the Campo Wind Facilities and Boulder Brush Facilities. Operations are scheduled to begin in fall 2020.

The development footprint would be confined to the minimal amount of area necessary for construction and safe and reliable operation. Development of new access routes would be limited to the maximum extent practicable. All construction areas, staging areas, and access roads would be clearly delineated in the final engineering plans.

Work Force: Installation of the Project as a whole would involve up to 561 construction workers on a daily basis. Construction would begin with site preparation; installation of civil improvements, including temporary staging areas for turbine deliveries; construction of access roads; installation of the underground runs for electrical cabling; construction of turbine, MET tower, gen-tie line pole, and transformer foundations; high-voltage substation pad; switchyard pad; and preparation of crane pads for erection of the turbines. Installation of electrical hardware (including cabling), construction of the collector substation, placement of the pad-mount transformers (if required), construction of the O&M facility, and erection of the turbines would follow. The final phase would include the completion of all wind turbine generators, high-voltage substation, and other facilities (including stringing the gen-tie line and paving access road to the high-voltage substation and switchyard); followed by commissioning and testing of each turbine, the substations, utility interconnection, and electrical system; and ~~restoration~~ revegetation of the temporary construction areas, staging areas, and turbine crane pads. Approximately 3 months of commissioning or testing would then be undertaken, or could be completed concurrently toward the end of construction.

Construction Communication and Contacts: The ability to communicate with personnel working on the Project Site is mandatory. The site safety officer and construction crews would be required to have a satellite phone, and/or radios that are operational within the area of work to report an emergency. Any radio units used during construction would comply with Federal Communications Commission's rules and regulations. Contact information for lead construction personnel would be provided to respective agencies. Communication pathways and equipment would be tested and confirmed operational each day prior to initiating construction activities. Fires and medical emergencies would be immediately reported to the Emergency Communication Center for San Diego County Fire Authority/CAL FIRE/Campo Reservation Fire Protection District.

Each on-site worker would carry at all times a laminated card listing 24-hour contact information, including telephone numbers for reporting an emergency and immediate steps to take if an incident occurs. Information on the card would be updated as needed and redistributed to workers before the initiation of any construction activities. The cards would be handed out by the site safety officer prior to construction kickoff so site staff can be provided training and receive their cards.

Additionally, the Developer and the Boulder Brush Developer would oversee the preparation of an Environmental Health and Safety Plan in compliance with Occupational Safety and Health Administration (OSHA) requirements, which would include identification of potential construction-related hazards, required personal protective equipment, work zones, safety considerations for site construction activities, as well as protocols regarding communications, accident or incident reporting, emergency response, and emergency medical treatment. As such, the Project would be in compliance with and Project employees and contractors would adhere to the emergency response procedures in the Environmental Health and Safety Plan.

Materials and Equipment: Construction equipment would consist of standard construction equipment such as graders, bulldozers, excavators, trenchers, backhoes, cranes, forklifts, delivery trucks (including concrete), semi-trucks, pick-up trucks, and sport utility vehicles. Table 1-1, Estimated Construction Equipment and Vehicles, lists construction equipment commonly associated with the construction and installation of wind facilities.

Construction Timing: Campo Wind Facilities construction would generally occur within the hours of 7:00 a.m. to 7:00 p.m. Some delivery activity at nighttime to accommodate requirements by California Department of Transportation (Caltrans) and/or the California Highway Patrol is expected. When activities on the Reservation must occur at night, all Project lighting (e.g., staging areas, equipment storage sites, roadway) would be directed downward and away from natural vegetation communities. Boulder Brush Facilities construction activities would occur during the County's allowable hours of operation (i.e., 7:00 a.m. to 7:00 p.m.), 6 days per week (Monday through Saturday), but may involve extended hours for material deliveries, as needed and as approved by the County. For example, placing concrete is dependent on temperature, so this

activity could be shifted to early morning depending on forecasted temperatures, and the gen-tie line crossing of I-8 would be subject to Caltrans approval and time requirements. Generally, all employees would arrive within the morning peak hour and depart within the evening peak hour, and delivery truck trips would be distributed throughout the 12-hour-shift day, between the hours of 7:00 a.m. and 7:00 p.m.

Site Preparation: Prior to construction, the limits of construction disturbance areas along roads, the electrical collection system, turbine and gen-tie line pole locations, O&M facility, substations, the switchyard, and staging areas would be clearly defined. All construction activities would be confined to these areas to prevent affecting sensitive areas.

Site Clearing, Grading, and Excavation: Construction would begin with vegetation clearing for the central staging areas. This would be followed and somewhat overlapped by clearing and grading of the new road alignments. Grading and vegetation clearing would take approximately 3 months with other phases occurring once access to that area is established, such as concrete batch plant set-up, while road grading continues. Vegetation would be cleared beginning with the areas necessary for access roads. As road grading progresses and Project features such as the temporary concrete batch plant, substations, and turbine sites becomes accessible, vegetation would subsequently be cleared from those areas. Cleared vegetation would be removed from the site and mulched for off-site reuse. Construction of components would begin with the establishment of one or both of the central staging areas.

Clearing and grading would be necessary for new access roads, widening existing access roads, turbine pads, MET tower pads, transmission poles, the O&M facility, the collector substation, the high-voltage substation, the switchyard, and the temporary concrete batch plant and staging areas. Clearing and grading would be accomplished using bulldozers, road graders, or other standard earth-moving equipment. Excavation would be necessary for foundations and ECCS construction, and would be accomplished using large excavators, backhoes, and trenching machines.

Clearing and grading associated with the Campo Wind Facilities would result in the net volume of cut to be redistributed throughout the Campo Wind Facilities site as fill. Clearing and grading associated with the Boulder Brush Facilities would result in balanced site, requiring approximately 26,800 cubic yards of cut and 26,800 cubic yards of fill. The Project's limits of grading and disturbance are shown in Figure 1-4. Limits of disturbance for Boulder Brush Facilities are also shown in Figures 1-4A through 1-4G.

Any new roads would minimize excessive grading and impacts to road embankments, ditches, and drainages. Roads would be located away from dry washes and drainage bottoms, to the greatest extent feasible, and would be designed to minimize surface water runoff and erosion and use the flow of the natural contours. The cut and fill required for the access roads would be balanced on site.

Construction Activities, SWPPP, and Erosion Control: Under the National Pollutant Discharge Elimination System (NPDES) Permit program, Stormwater Pollution Prevention Plans (SWPPPs) are prepared by the construction contractor and best management practices (BMPs) identified in the SWPPPs are implemented for construction sites greater than one acre, in order to reduce the occurrence of pollutants in surface water. In compliance with applicable construction permits, the Project would implement BMPs that minimize disturbance, protect slopes, reduce erosion, manage stockpiles and storage areas, and limit or prevent various pollutants from entering surface water runoff. Private development projects, like the Project, are required to implement these measures to ensure that pollutant discharges and runoff flows from development are reduced to the maximum extent practicable; and receiving water quality objectives are not violated throughout the life of the Project. These measures are listed in the Minor Stormwater Quality Management Plan prepared for the Project and includes details of construction and post-construction BMPs to address potential and anticipated water quality impacts.

Separate SWPPPs are required for the Campo Wind Facilities and the Boulder Brush Facilities. The SWPPPs would be prepared as part of the U.S. Environmental Protection Agency's NPDES Multi-Sector General Permit for Storm Water Discharges, and would document the selection, design, and installation of stormwater control measures, which could include the following:

- Silt fences, straw bales, fiber rolls, sedimentation ponds, and rainfall diversion ditches
- Restoration of all disturbed areas to include re-contouring the area; stockpiling and then reapplying topsoil; and reseeded the area with a mixture of native grasses, forbs, and shrubs
- Installation of silt fences and/or straw bales at road drainage outlets to prevent soil erosion and drainage into water courses
- Strategic placement of stockpiled materials (e.g., debris, excess soil) such that it cannot reach water courses

In accordance with the SWPPPs, topsoil stockpiles would be stabilized and protected to prevent run-off and wind erosion during storm events or windy conditions. As described in this construction design feature (**PDF-CON-4**), temporary-cover BMPs to protect stockpiles would include measures such as seeding, mulches, matrices, blankets and mats, the use of soil binders, and positioning of fiber rolls and silt fence around stockpile areas. Additionally, temporary disturbance areas would be reseeded with native species in accordance with applicable requirements.

Final Road Grading, Erosion Control, and Site Cleanup and Stabilization: Once construction is complete, disturbed areas would be graded to the approximate original contour, as feasible, and any remaining trash and debris would be properly disposed of off-site. Areas disturbed during construction would be stabilized and reclaimed using appropriate erosion control measures,

including site-specific contouring, reseeding, or other measures designed and implemented in compliance with the SWPPPs, and Revegetation Plans. Separate plans are required for the Campo Wind Facilities and the Boulder Brush Facilities. Upon completion of construction of the Campo Wind Facilities, existing land uses would be able to continue with minimal impacts.

During final road grading, surface flows would be directed away from cut-and-fill slopes and into ditches that outlet to natural drainages. The Developer and the Boulder Brush Developer would prepare and implement a SWPPP, which would include standard sediment control devices (e.g., silt fences, straw bales, netting, soil stabilizers, check dams) to minimize soil erosion during and after construction. Waste materials would be disposed of at approved and appropriate landfills. Following construction, the Developer and the Boulder Brush Developer would ensure that all unused construction material and waste is picked up and removed.

Contractors would provide trash barrels or dumpsters to collect all construction waste for proper disposal at an approved facility, as well as recycling bins for plastics and aluminum cans. No waste disposal by incineration would occur. The Developer and the Boulder Brush Developer would inspect and clean up the Project development footprint following construction to ensure that no solid (e.g., trash) or liquid (e.g., used oil, fuel, turbine lubricating fluid) waste was inadvertently spilled or left on site.

Cleanup crews would patrol the construction site on a regular basis to remove litter. Final site cleanup would be performed prior to shifting responsibilities to O&M staff.

Testing and Commissioning: Project testing would involve mechanical, electrical, and communications inspections to ensure that all systems are working properly. Performance testing would be conducted by qualified wind power technicians and would include checks of each wind turbine and the SCADA system prior to turbine commissioning. Electrical tests of the Project (i.e., turbines, transformers, and underground ECCS) and transmission system (i.e., gen-tie line and high-voltage substation) would be performed by qualified electricians to ensure that all electrical equipment is operational within industry and manufacturer tolerances and installed in accordance with design specifications. All installations and inspections would be in compliance with applicable codes and standards.

Construction Water: An estimated maximum water demand of approximately 173 acre-feet (AF) of water would be required over the 14 months of construction (123 AF for Campo Wind Facilities and 50 AF for Boulder Brush Facilities). Approximately 250,000 gpd would be required during peak construction demand, which would occur over the first 3 months of construction. For the remainder of Project construction, water demand would be reduced to approximately 120,000–150,000 gpd. This water would be used for concrete mixing, dust suppression, and other tasks. Nontoxic soil stabilizers may be used as an alternative dust-suppression method, which would

considerably reduce construction water demand. These conservative water-demand estimates do not account for use of these stabilizers. Water sources during construction would include On- and Off-Reservation facilities such as production wells on the southern end of the Reservation and commercially obtained non-potable water from permitted Off-Reservation purveyors such as JCSD and PDMWD.

Boulder Brush Facilities

Water would be required during the construction phase of the Boulder Brush Facilities and would be trucked to the site from JCSD or PDMWD during construction.

Water would be used for road construction, concrete mixing, dust suppression, and fire protection. A total of approximately 50 AF of water would be used during construction, a breakdown of water usage for the Boulder Brush Facilities as follows:

1. ***Foundation Concrete Mixing*** – It is estimated approximately 15 AF of water would be required for concrete mixing during construction, to be prepared at the temporary batch plant to be located on the Reservation.
2. ***Dust Suppression*** – It is estimated that a total of 35 AF would be used for dust suppression during construction, including access road grading and construction. Magnesium chloride, a natural element, would be applied during construction of access roads to reduce fugitive dust and the need for water during this phase.
3. ***Fire Protection*** – The Project would be equipped with up to three water trucks, each with a 4,000-gallon capacity, during construction.

Campo Wind Facilities

During construction, water would be used for road construction, concrete mixing, dust suppression, and fire protection. A total of approximately 123 AF of water would be used during construction, a breakdown of water usage on the Reservation is as follows:

1. ***Foundation Concrete Mixing*** – It is estimated approximately 36 AF of water would be required for concrete mixing during construction, to be prepared on-site at the batch plant.
2. ***Dust Suppression*** – It is estimated that a total of 87 AF would be used for dust suppression during construction, including access road grading and construction. Magnesium chloride, a natural element, would be applied during construction of access roads to reduce fugitive dust and the need for water during this phase.
3. ***Fire Protection*** – The Project would be equipped with up to three water trucks, each with a 4,000-gallon capacity, during construction.

Concrete Quantities: Sand, aggregate, and cement would be sourced from existing local and permitted quarries. Concrete would be mixed at the temporary batch plant on the Reservation and delivered by truck to the components needing foundations (wind turbines, MET towers, O&M facility, transmission poles, collector substation, high-voltage substation, and switchyard).

Boulder Brush Facilities

Cement would be mixed at the temporary batch plant on the Reservation and delivered by truck to the components needing foundations (Off-Reservation gen-tie line poles, high-voltage substation, and switchyard). Approximately 700 cubic yards of concrete would be used for the Boulder Brush Facilities and for the transmission poles associated with the incoming and outgoing connection lines to be constructed by SDG&E.

Campo Wind Facilities

Cement would be mixed on site at the temporary batch plant on the Reservation and delivered by truck to the components needing foundations (On-Reservation gen-tie line poles, turbines, MET towers, collector substation, and O&M facility). Approximately 37,000 cubic yards would be used for the Campo Wind Facilities.

1.2.2.1 Construction of Boulder Brush Facilities

Construction of specific components of the Boulder Brush Facilities are described herein. Additionally, the following construction-related project design features would be implemented as part of the Boulder Brush Facilities:

PDF-CON-1 On-site access roads would be staked at the outermost perimeter of 40 feet, to ensure no Project personnel go beyond these boundaries. Stakes would be placed every 200 feet in accordance with industry standards. Additionally, on-site construction workers performing ground-disturbance activities would be equipped with GPS units that would clearly delineate the limits of grading.

PDF-CON-2 Prior to construction of roadway improvements, the off-site, up to 30-foot roadway improvement boundaries would be marked by stakes every 200 feet in accordance with industry standards, to delineate the extent of allowed grading limits. Additionally, on-site construction workers performing ground-disturbance activities would be equipped with GPS units that would clearly delineate the limits of grading.

PDF-CON-3 Prior to the issuance of a grading permit for Boulder Brush Facilities, the Worker Environmental Awareness Program (WEAP) training for on-site personnel would be submitted for approval to the County. The County may require additional

information to be added to the WEAP training, and must approve the finalized WEAP training prior to its implementation. All Boulder Brush Facilities personnel would be required to attend the WEAP training prior to working on site and monthly updated lists, to include full name, phone number, and position/company of personnel who have received the WEAP training, would be provided to the County. In addition, temporary personnel delivering equipment and supplies to the site would be aware of the requirements and required to comply with the WEAP training, including, but not limited to, speed limit, stopping for wildlife observed in the access road, driving within the approved right-of-way, observing bird buffer signs and not stopping within the buffers, and driving slower than the approved speed limit, should dust occur on the access road.

PDF-CON-4 Stockpiles of soil shall be properly contained to eliminate or reduce sediment transport from the site to on-site access roads, drainage facilities, or adjacent properties via runoff, vehicle tracking, or wind. Stockpiles would be stabilized using temporary cover best management practices to protect stockpiles and prevent erosion and runoff through the application of seeding, soil blankets, mulches, mats, soil binders, positioning of fiber rolls and silt fence around the stockpile, or other cover on bare soil. Additional methods such as applying water or installing wind barriers should also be used to reduce wind erosion. Temporary disturbance areas would be reseeded with native species in accordance with the applicable requirements.

PDF-CON-5 Blasting operations would be in general conformance with the blasting specifications prepared by the U.S. Bureau of Mines and the blasting permit requirements issued by the County. The blasting contractor would be required to limit the blasting intensities so as to prevent damage to all existing structures, and in no case would intensities exceed the safety standard of particle velocity recommended by the U.S. Bureau of Mines. Also, air-borne noise from drilling operations is regulated through Section 36.410 of the County's noise ordinance.

1) Off-Reservation Gen-Tie Line

Work on the approximately 3.5 miles of gen-tie line within the Boulder Brush Corridor on private land would begin with construction of a new access road to the new switchyard and new access roads to the gen-tie line steel pole structures. The gen-tie line access roads would be graded and would generally be 16 feet wide for straight sections and up to 20 feet wide at curves to allow for the safe access of construction equipment and vehicles. Access roads to the gen-tie line structures would be compacted decomposed granite, but the main access road to the high-voltage substation and switchyard would ultimately be finished as an up to 30-foot-wide paved road.

Engineered steel poles would be drilled on pier foundations for turning or dead-end structures and directly embedded structures for tangential poles. Each transmission line pole would be set on a concrete foundation, with the hole dimensions approximately 8 feet wide by 25 feet deep. Pole holes would be excavated using a truck-mounted drill rig and poles would then be delivered on a flat-bed trailer and hoisted into place by a crane. Where required for pier foundations, steel cages and anchor bolt cages would be set in the open hole for reinforcement. Directly embedded structures would be backfilled with native excavated material or light concrete mixture, depending on specific conditions for each pole site. Any remaining excavated material would be placed within areas disturbed during the construction of Boulder Brush Facilities.

Installation of the new 230 kV conductor would require pull sites along the gen-tie line route. Generally, pull sites would be approximately 100 feet by 150 feet and would be required where 230 kV angle structures are located. The sites would be needed to load the tractors and trailers with reels of conductors and the trucks with tensioning equipment. Pull sites would be minimally grubbed (e.g. bush-hogging) and minimally graded, if needed.

After the conductor has been pulled into place, the sag between the structures would be adjusted to a pre-calculated level and the line would be installed. The conductor would then be attached to the end of each insulator, the sheaves would be removed, and the vibration dampers and other accessories would be installed.

2) High-Voltage Substation

Once road access to the high-voltage substation site has been provided, grading and preparation of the high-voltage substation site would follow. The site would be cleared, graded, and prepared to enable adequate access for construction equipment and activities. Site grading would require the use of bulldozers and scrapers to cut and fill native soil to the proposed pad elevation. Additional equipment, including backhoes and drill rigs, would be used to excavate foundations, and concrete mixed at the temporary concrete batch plant would be used to build the foundation/substation pad. Construction would continue with installation of the various concrete footers and foundations needed for the circuit breakers, control ~~houses~~shelter, and main transformer that would be installed in the substation area. A grounding mat, installed and then covered in gravel, would be the final ground surface of the high-voltage substation. Steel structures, various electrical equipment, and fencing around the substation would then be installed. The facility would be fenced with up to 8-foot-tall fencing consisting of a 6-foot-high chain-link fence with an additional 2 feet of security wiring located at the top.

3) 500 kV Switchyard and Connection to the Existing SDG&E Sunrise Powerlink

Construction of the switchyard would begin with clearing vegetation and organic material from the switchyard site. The switchyard site would then be excavated to frame and pour foundations.

Structural footings and underground utilities, along with electrical conduit and grounding grid, would be installed, followed by aboveground structures and equipment. An up to 30-foot-tall fence, as required by SDG&E, would be constructed around the switchyard for security and to restrict wildlife and unauthorized persons from entering the facility.

Construction of the incoming and outgoing 500 kV connection lines would be performed by SDG&E and would include installing approximately 12 steel transmission structures, stringing high-voltage transmission wires, and tension pulling the wires. Because the incoming and outgoing connection lines would be constructed by SDG&E, they are subject to the jurisdiction of the California Public Utilities Commission for both construction and operation. After the switchyard is constructed and transferred to SDG&E, its operation would also be under California Public Utilities Commission jurisdiction.

4) Access Roads

The proposed new 3.5-mile access road from the existing paved Ribbonwood Road to the high-voltage substation and switchyard would be constructed up to 30 feet in width and paved. Twenty (20) feet of fuel modification would be maintained on each side of this road within the Boulder Brush Boundary. Otherwise, subject to County approval, the width of fuel modification on each side of this road from the intersection at Opalocka Road to the Boulder Brush Boundary would be contingent upon available land within the access easements that this segment of the access road traverses. Approximately 2.6 miles of the new 3.5-mile paved road would serve as direct access to approximately 24 Off-Reservation gen-tie line pole structures that would run parallel to this road (refer to Figure 1-4 and Figure 1-9B). The remaining eight Off-Reservation gen-tie line poles within the Boulder Brush Corridor that are not adjacent to the paved road would be accessed by compacted decomposed granite (16 feet in width). Road improvements would consist of increased graded width in areas, particularly corners or bends, and improved crossings involving addition of blocks for stability or increased length of culverts as necessary. The portions of increased road width necessary for construction activities but not required for operations and maintenance would be removed upon completion of construction and revegetated in accordance with the applicable requirements.

All unpaved access roads would consist of compacted native material and may also have approximately 4 to 6 inches of aggregate and/or geosynthetic material to provide the soil strength needed for construction. The temporary disturbance areas outside the final roadway width would be graded and compacted for use during construction and then de-compacted and stabilized at the conclusion of construction. An approximately 20-foot-wide fuel modification zone would be maintained on either side of the on-site unpaved access roads for the Boulder Brush Facilities. All on-site roads within the Boulder Brush Boundary would be privately maintained.

Depending on the soil subsurface, surface soils may need to be excavated and replaced with gravel and/or sand to sufficiently establish a stable road base. Roads would be located away from drainage bottoms, steep slopes, and erodible soils if practicable and would be designed to maintain current surface water runoff patterns and prevent erosion. Soil erosion would be controlled at culvert outlets with appropriate structures. Catch basins, roadway ditches, and culverts would be cleaned and maintained regularly. If road grade and/or runoff patterns result in added erosion, control measures would be installed to minimize the added erosion.

5) Defensible Space (Fuel Modification Zones)

The Boulder Brush Facilities would be provided defensible space by a Fuel Modification Zone (FMZ) buffer around each gen-tie line pole, the high-voltage substation, and the switchyard. FMZs would be maintained on at least an annual basis or more often, as needed. Planting, if applicable, used in the defensible space would consist of low-growing ground cover selected from the SDCFA desirable plant list. A potential plant mix for the FMZ areas is included in Appendix I of this EIR. The seed mix would be reviewed and approved by the SDCFA Fire Marshal and included in the Revegetation Plan prepared for the Boulder Brush Facilities. The high-voltage substation and switchyard within the Boulder Brush Boundary would include contiguous FMZ of 50 feet around the perimeter fence (approximately 100 feet from the electrical components on the pad areas). The high-voltage substation pad area would be free of vegetation around all electrical equipment. It is recommended that the Campo Wind Facilities provide defensible space by a FMZ buffer around facilities, similar to the Boulder Brush Facilities. FMZ requirements and vegetation management specific to the Campo Wind Facilities will be outlined in the FPP prepared to the satisfaction of the Campo Reservation Fire Protection District for the Campo Wind Facilities. Defensible space and fuel modification zones are described in detail within Section 2.9, Wildfire, of this EIR, and the Boulder Brush Facilities Fire Protection Plan, Appendix I to this EIR.

1.2.2.2 Construction of Campo Wind Facilities

Construction of specific components of the Campo Wind Facilities are described herein. In addition, and consistent with the EIS, the following PDFs would be implemented as part of Campo Wind Facilities construction:

- PDF-AQ-1** Prior to the Campo Band of Diegueño Mission Indians' (Tribe) approval of any construction-related permits, the lessee or its designee shall place the following requirements on all plans, which shall be implemented during each construction phase to minimize volatile organic compound (VOC), carbon monoxide (CO), and oxides of nitrogen (NO_x) emissions:
- a. Prior to the commencement of any construction activities, the lessee or its designee shall provide evidence to the Tribe that for off-road equipment with engines rated at 75 horsepower or greater, no construction equipment shall be

used that is less than Tier 4 Final. An exemption from these requirements may be granted by the Tribe in the event that the applicant documents that equipment with the required tier is not reasonably available and corresponding reductions in criteria air pollutant emissions are achieved from other construction equipment. Before an exemption may be considered by the Tribe, the applicant shall be required to demonstrate that three construction fleet owners/operators in the San Diego region were contacted and that those owners/operators confirmed Tier 4 Final equipment could not be located within the San Diego region.

- b. Vehicles in loading and unloading queues shall not idle for more than 5 minutes and shall turn their engines off when not in use to reduce vehicle emissions.
- c. All construction equipment shall be properly tuned and maintained in accordance with manufacturer's specifications.
- d. The use of electrical or natural gas-powered construction equipment shall be employed where feasible, including forklifts and other comparable equipment types.

PDF-AQ-2 Fugitive Dust Control. The Developer or its designee shall implement the following measures to minimize fugitive dust (coarse particulate matter [PM₁₀] and fine particulate matter [PM_{2.5}]):

- a. Water or other approved dust control non-toxic agent shall be used on the grading areas at least three times daily.
- b. All main roadways to be paved shall be constructed and paved as early as possible in the construction process.
- c. Grading areas shall be stabilized as quickly as possible.
- d. Chemical stabilizer shall be applied, a gravel pad shall be installed, or the last 100 feet of internal travel path within the construction site shall be paved prior to public road entry and for all haul roads.
- e. Wheel washers shall be installed adjacent to the apron for tire inspection and washing prior to vehicle entry on public roads.
- f. Visible track-out into traveled public streets shall be removed with the use of sweepers, water trucks, or similar method within 30 minutes of occurrence.
- g. Sufficient perimeter erosion control shall be provided to prevent washout of silty material onto public roads.
- h. Unpaved construction site egress points shall be graveled to prevent track-out.

- i. Construction access points shall be wet-washed at the end of the workday if any vehicle travel on unpaved surfaces has occurred.
- j. Transported material in haul trucks shall be watered or treated.
- k. All soil disturbance and travel on unpaved surfaces shall be suspended if winds exceed 25 miles per hour.
- l. On-site stockpiles of excavated material shall be covered.
- m. A 15 mile per hour speed limit on unpaved surfaces shall be enforced.
- n. Construction Traffic Control Plans shall route delivery and haul trucks required during construction away from sensitive receptor locations and congested intersections to the extent feasible. Construction Traffic Control Plans shall be finalized and approved prior to issuance of grading permits.

PDF-AQ-3 The following measures shall be included as part of the Fugitive Dust Control Plan for the Campo Wind Facilities to reduce emissions associated with blasting and rock-crushing activities:

- a. During blasting activities, the construction contractor shall implement measures to control fugitive dust, including exhaust ventilation, blasting cabinets and enclosures, vacuum blasters, drapes, water curtains, or wet blasting. Watering methods, such as water sprays and water applications, shall be implemented during blasting, rock crushing, cutting, chipping, sawing, or any activity that would release dust particles to reduce fugitive dust emissions.
- b. During rock crushing transfer and conveyance activities, material shall be watered prior to entering the crusher. Crushing activities shall not exceed an opacity limit of 20% (or Number 1 on the Ringelmann Chart) as averaged over a 3-minute period in any period of 60 consecutive minutes. A qualified opacity observer shall monitor opacity from crushing activities once every 30 days while crushers are employed on site. Water sprayers, conveyor belt enclosures, or other mechanisms shall be employed to reduce fugitive dust generated during transfer and conveyance of crush material.

PDF-AQ-4 All Campo Wind Facilities phases involving blasting shall conform to the following requirements:

- Each blasting event shall employ approximately 1.2 tons of ammonium nitrate/fuel oil (ANFO).
- Blasting activities shall be restricted to not more than two blasts per day.
- All blasting shall be performed by a blast contractor and blasting personnel licensed to operate in the County.

PDF-AQ-5 Construction Architectural Coating Limits. The Campo Wind Facilities shall comply with the following volatile organic compound (VOC) content limits for architectural coatings during construction for residential and non-residential and uses: 50 grams per liter VOC for interior surfaces and 100 grams per liter VOC for exterior coatings.

PDF-TR-1 Construction Traffic Control Plan. Prior to construction of the Campo Wind Facilities, the Developer shall prepare and implement a Construction Traffic Control Plan.

a) Wind Turbines

Wind turbine construction would include grading the turbine and crane pads, foundation construction, tower erection, nacelle, blade and rotor installation, pad-mount installation (if necessary), miscellaneous mechanical and electrical installation, finish grading, rock ring installation around the outside of the tower, and finally ~~restoration~~ revegetation of the temporary disturbed ground and vegetation. Turbine components would be delivered on oversized trucks in coordination with Caltrans and California Highway Patrol. No Off-Reservation roads would be used for the delivery of oversized turbine components, except I-8.

An approximately 1.9-acre temporary construction area for each wind turbine site would require clearing and grading for the crane pad, equipment laydown, and other construction-related needs. An excavator or dozer would be used for clearing and grading each turbine site. Grading would only occur where necessary and as specified by the Project's final engineering plans. Silt fencing would be placed at the limits of disturbance to control erosion consistent with the NPDES. Within this temporary construction area, a 60-foot by 100-foot crane pad is required for supporting the large tower erection crane. The crane pad would consist of a compacted native soil or compacted aggregate base gravel area. Upon completion of wind turbine construction, gravel with a minimum approximately 16-foot width would be placed around each approximately 20-foot-diameter reinforced-concrete turbine pedestal to provide truck access.

Wind turbine foundation design would be based on geotechnical and structural design parameters, wind turbine manufacturer requirements, local design codes, and standards of the wind turbine industry, as determined by the Project's certified professional engineer. It is expected that foundations would be approximately 70–80 feet in diameter and 7–10 feet below grade (exact dimensions would depend on specific site needs). Once the soil has been excavated and compacted, the framework of the foundation would be constructed of rebar and anchor bolts. After the foundation framework is built, concrete has been poured, and the foundation has cured, the area around the foundation would be backfilled and graded with stockpiled subsoil (at lower levels) and topsoil. Each concrete foundation would incorporate approximately 600–650 cubic yards of concrete. Each turbine foundation may also include a 5-foot by 9-foot concrete pad if the turbine uses a pad-mount transformer. A licensed geotechnical engineering firm would oversee foundation

design and construction to ensure that the recommendations provided in the geotechnical investigation are followed.

Turbine towers, nacelles, and blades would be erected in three phases. Each tower would be fabricated, delivered, and erected in four to six sections. The phases would be as follows:

- (1) The first phase would consist of installation of the switch gear and tower base (the bottom level of the tower sections) over the foundation anchor bolts. The tower base would be leveled, and high-strength grout would be applied in the space between the tower and the foundation.
- (2) The second phase would consist of installation of multiple tower sections to complete the tower.
- (3) The third phase would consist of installation of the nacelle, connecting it to the tower, and the full rotor assembly (including hub with three blades attached).

Turbine component deliveries would be coordinated so that components are delivered directly to wind turbine worksites where foundations have been built and backfilled, and where crane pads have been constructed. This eliminates “double handling” of the wind turbine components. Delivery trucks would pull up to each wind turbine worksite where cranes would offload the components to determined areas at the worksite where they would be prepped for later erection by a wind turbine erection team.

Construction cranes, such as a hydraulic support crane and the main crawler crane, would be used to assemble the wind turbines. The main crawler crane has a lifting capacity of approximately 400 tons and would be assembled on site. Once assembled, the main crawler crane has a track width of approximately 30 feet and is able to move slowly across relatively level terrain. Disassembly and reassembly of the main crawler crane can take up to 1 day to complete. It is anticipated that the main crawler crane(s) would move between wind turbines by following the Project access roads. In places where access roads do not link wind turbine sites, it would be necessary to perform partial or full crane re-assemblies to move the crane.

To support the construction crane during turbine erection, a compacted-soil crane pad (approximately 60 feet by 100 feet with a maximum slope of 1%) would be required at each wind turbine location. The underlying soils would be compacted to a soil-bearing capacity of 6,000 pounds per square foot to provide a stable foundation for the crane. The site would be leveled by blasting (if necessary) and grading. Where the site topography precludes such methods from achieving a 1% slope, a crane mat would be used (instead of a crane pad) to achieve the 1% slope.

Blasting and rock crushing may be required depending on the outcome of the geotechnical analysis and recommendations. Blasting would occur during the grading and access road construction phases. No more than two blasts per day would occur, and blasting would only occur in isolated locations where the geotechnical conditions at those locations necessitate blasting.

The wind turbine erection crew would lift the wind turbine base section and bolt it to the foundation anchor bolts. Typically, constructors would elect to next assemble the wind turbine rotor on the ground. The hub would be positioned in a relatively flat location and a small crane would be used to lift the three blades in place so that they can be bolted to the hub. With the base set, additional sections (typically towers are manufactured with multiple sections) would then be set and bolted in place. The final set of operations would be performed by the main crawler crane and is typically done in a relatively short period (approximately 4 hours in some cases). The main crawler crane would first lift the nacelle atop the tower and then lift the rotor so that ironworkers can bolt it to the nacelle. Upon installation of the rotor, all crane-dependent work would be completed for the wind turbine, and the main crawler crane would be relocated to complete assembly of another wind turbine. The rotor assembly of the nacelle would include a rotor hub (the 6- to 10-foot “nose cone” onto which the blades are bolted) and three turbine blades. The rotor hub would bolt to the drive train at the front of the nacelle. Rotor blades are typically made from a glass-reinforced polyester composite.

After the turbine has been erected, native soil would be used within the area surrounding the base of the turbine tower to a distance of approximately 16 feet. Native soil would be used to provide a stable surface for maintenance vehicles and to minimize surface erosion and runoff.

b) Access Roads

Campo Wind Facilities access roads would be constructed of native soils with decomposed granite and gravel, or similar suitable materials, to provide access in nearly all-weather conditions. All roads would be constructed or upgraded in accordance with industry standards. Bulldozers and graders would be used to build and widen roads, and a water truck would be used for road compaction and dust control. Compaction requirements to build embankments for roads and compaction equipment would be determined by the geotechnical engineer of record for the Project.

Due to the length of the turbine blades and heavy turbine components, roadways may require upgrades and modifications to accommodate blade delivery and large delivery trucks and cranes. The Project includes the construction of new dirt access roadways and improvements to existing roadways to access the Project. Temporary access roads between turbine sites would be constructed at up to 40-foot widths to allow for large crane movement within the site. Permanent access roads between turbines for use during Campo Wind Facilities operations would be reduced down to 24 feet wide after project commercial operations. All unpaved access roads would consist of compacted native material and may also have approximately 4 to 6 inches of aggregate and/or geosynthetic material to provide the soil strength needed for construction. The temporary disturbance areas outside the final roadway width would be graded and compacted for use during construction and then de-compacted and stabilized at the conclusion of construction.

Depending on the soil subsurface, surface soils may need to be excavated and replaced with gravel and/or sand to sufficiently establish a stable road base. Roads would be located away from drainage bottoms, steep slopes, and erodible soils if practicable and would be designed to maintain current surface water runoff patterns and prevent erosion. Soil erosion would be controlled at culvert outlets with appropriate structures. Catch basins, roadway ditches, and culverts would be cleaned and maintained regularly. If road grade and/or runoff patterns result in added erosion, control measures would be installed to minimize the added erosion.

c) Electrical Collection and Communications System

Approximately 28 miles of underground ECCS cable would be installed in temporary trenches to connect each wind turbine to the collector substation. There would be three cable conductors, one grounding wire, and one fiber-optic cable installed per trench approximately 4 feet below grade. A red warning tape stating “Buried Cable” or similar would also be placed in the trench above the cables and approximately 1 foot below grade.

The underground ECCS would be routed to minimize the overall cable length required for the Project and to lessen the temporary impacts associated with the trenching. For example, cables would be routed in parallel and/or adjacent to access roads to the extent feasible. However, in some cases, trenches would run overland from the end of one turbine string to an adjacent string. Each trench would be approximately 2–4 feet wide and 4 feet deep. An additional approximately 14 feet of temporary disturbance alongside the trench would be required to account for trenching equipment and temporary placement of excavation. Depending on terrain, an approximately 40-foot-wide area may be required to install portions of the underground ECCS cables using a combination of trenching, open excavation, and directional boring. In addition, certain areas may not be feasible for trenching due to solid rock, large boulders, or subsurface resources. In these instances, a temporary worksite 15 feet to 20 feet wide may be required to enable construction of overhead ECCS circuits. These overhead circuits would be supported on steel/concrete/wood monopoles up to 60 feet in height that would be spaced approximately 450 feet apart. Junction boxes for access to underground cables for inspection, maintenance, and repair would be installed at approximately 0.2-mile intervals. Once installed, the disturbed areas would be revegetated with a native seed mix.

Where underground ECCS cables must cross public roadways, installation can be accomplished using directional boring equipment to minimize traffic and roadbed impacts. Specific construction of each underground ECCS road crossing would be coordinated with the appropriate highway departments (BIA, Tribal, County, or state) responsible for the affected road(s). The directional boring technique involves digging a relatively small pit on one side of the road and then using a rotating bit to “drill” under the road. Cables are then pulled through the route created by the directional boring machine. Directional boring is a relatively costly installation technique for limited distances. However, directional boring is useful in situations where minimizing road and environmental impacts is important. In the event an ephemeral stream crossing is necessary, design would be coordinated with the U.S. Army Corps of Engineers to minimize impacts to sensitive areas.

d) Collector Substation

Once access to the collector substation site has been provided, site grading and preparation would follow. Approximately 3 acres would be cleared and graded to enable adequate mobility for construction equipment and activities. Site grading would require the use of bulldozers and scrapers to cut and fill native soil to the proposed pad elevation. Additional equipment, including backhoes and drill rigs, would be used to excavate foundations, and concrete mixed at the temporary concrete batch plant would be used to build the foundation/substation pad. Structural footings and underground utilities, along with electrical conduit and grounding grid, would be installed, followed by aboveground structures and equipment. Construction would continue with installation of the various concrete footers and foundations needed for the circuit breakers, control housesshelter, and main transformer that would be installed in the collector substation area. A grounding mat, installed and then covered in gravel, would be the final ground surface of the collector substation. Steel structures, various electrical equipment, the two 10,000-gallon water tanks dedicated for firefighting purposes, and fencing around the collector substation would then be installed. A chain-link fence would be constructed around the new collector substation for security and to restrict wildlife and unauthorized persons from entering.

e) O&M Facility

The O&M facility would be constructed during the first stage of construction after roadways and access to the Campo Wind Facilities site is developed. The O&M facility would be located within one of the two central staging areas on the Reservation which would be fenced for safety. The O&M building would be a single-story prefabricated structure approximately 18 feet in height. The approximately 6-acre area would include parking areas and storage. The surfacing would be compacted decomposed granite overlaid with gravel. The O&M facility would require a potable water source for employee uses; therefore, an on-site water tank for potable water would be located within the footprint of the O&M facility in the event that other water is not available. In addition, two 10,000-gallon water tanks dedicated for firefighting purposes would be installed at the O&M facility.

f) Meteorological Towers

Construction work areas would be cleared for each permanent MET tower location. These work areas would vary in size due to topography, requiring an approximately 0.3- to 0.5-acre area around each permanent tower to be cleared and leveled. The construction work area would be necessary for foundation excavation and construction, assembly of MET tower sections, and staging of the construction crane, which would hoist the lattice tower sections into place.

To support the construction crane for MET tower erection, a compacted-soil crane pad with a maximum slope of 1% would be required. The underlying soils would be compacted to provide a soil-bearing capacity designed to provide a stable foundation for the crane.

Permanent MET tower foundations would be buried underground. Although exact dimensions would depend on the geotechnical survey, site-specific needs, and the final hub height of the wind turbines, the foundations for un-guyed, self-supporting, lattice structures would typically be approximately 26 feet by 26 feet. The towers would be enclosed within an approximately 50-foot by 50-foot perimeter by an 8-foot-tall chain-link fence with locked gates. All other cleared areas associated with construction would be revegetated.

Temporary MET towers would be installed by crane at specified turbine locations that would have already been graded and prepared for turbine construction. Therefore, no incremental site preparation work would be required. These towers would require much smaller concrete foundations than the permanent MET towers because they would be supported by guy wires. Upon collecting sufficient site-specific wind data, these towers would be removed.

g) Water Collection and Septic Systems

In the event that on-site well water is available, a water collection system would be constructed for operational purposes and would consist of incidental trenching and grading along areas to be disturbed for access or ECCS purposes. All water facilities for operations would be located within the Reservation and not subject to County jurisdiction. In addition, sewage disposal is anticipated via an approved septic system nearby on the Reservation and not subject to County jurisdiction.

h) Temporary Concrete Batch Plant for Use during Construction

After access to the temporary batch plant site on the Reservation is provided, the batch plant area of approximately 400 feet by 400 feet, or 3.7 acres, would be cleared and minimally graded including installation of temporary BMPs. Areas would be assigned for the concrete mixing, for aggregate and sand stockpiling, ingress and egress, truck load-out area, and turnaround(s). Sand, aggregate, concrete, and water would be delivered to the temporary concrete batch plant and stored in stockpiles until use. The temporary batch plant area would be removed upon completion of construction and revegetated in accordance with applicable requirements.

i) Temporary Staging and Parking Areas for Use during Construction

Two central, On-Reservation temporary staging areas of approximately 20 acres total would be cleared and graded, including installation of temporary BMPs. The staging areas would provide for construction-management facilities, materials and equipment storage, and worker parking. Vehicle parking would be clearly marked and limited to areas away from sensitive habitat. The staging areas would require a temporary tap to an existing electrical distribution line to provide power throughout construction. This would require a temporary construction right-of-way of approximately 1,000 feet by 12 feet (0.28 acres). The temporary distribution line tap would require the installation of up to 10 wooden distribution poles within this temporary right-of-way, which

would take approximately 1 month to install. Generators would be placed at the staging areas and would be used until the temporary tap is complete.

Temporary security fencing (6-foot-tall chain-link fencing) may be placed around all or parts of the central staging areas to limit public and wildlife access. When construction is complete, the fencing would be removed. The O&M facility would be constructed at one of the staging areas; the land outside of the O&M facility footprint would be revegetated. The other temporary staging area would be removed upon completion of construction and revegetated in accordance with applicable requirements.

j) On-Reservation Gen-Tie Line

The approximately 5 miles of On-Reservation gen-tie transmission line would begin with construction of new or improved access roads to the gen-tie line steel pole structures. These roads would be graded and would generally be 16 feet wide for straight sections and up to 20 feet wide at curves to allow for the safe access of construction equipment and vehicles. Access roads to the gen-tie line structures would be decomposed granite and gravel roads.

Engineered steel poles would be drilled on pier foundations for turning or dead-end structures and directly embedded structures for tangential poles. Each turning or dead-end steel pole would be set on a concrete foundation pier, with a hole dimension of approximately 24 inches in diameter and up to approximately 25 feet deep. Each tangential structure would be directly augered into up to 24-inch holes, backfilled with native soils, and then compacted. Pole holes would be excavated using a truck-mounted drill rig; poles would then be delivered on a flatbed trailer and hoisted into place by a crane. Poles associated with the I-8 crossing would involve foundations with pole hole of approximately 36 inches in diameter by up to approximately 36 feet deep.

Installation of the new 230 kV conductor would require pull sites along the gen-tie line route. Generally, pull sites would be approximately 100 feet by 150 feet and would be required where 230 kV angle structures are located. The sites would be needed to load the tractors and trailers with reels of conductors and the trucks with tensioning equipment. After the conductor has been pulled into place, the sag between the structures would be adjusted to a pre-calculated level and the line would be installed. The conductor would then be attached to the end of each insulator, the sheaves would be removed, and the vibration dampers and other accessories would be installed. As mentioned above, approximately 5 miles of the 230 kV gen-tie line, including approximately 42 support poles, would be located on the Reservation.

1.2.2.3 Decommissioning

The Project is anticipated to operate for the term of the Campo Lease and any renewal extension (approximately 30 years, at minimum), after which it would be decommissioned, except for the SDG&E-owned and operated switchyard and connection lines to Sunrise Powerlink, which would

not be decommissioned. All decommissioning would occur within the Project Site and disturbance limits, and would involve similar, though reduced construction equipment and activities.

The Boulder Brush Developer would be responsible for decommissioning of the Boulder Brush Facilities, with the exception of the facilities owned and operated by the SDG&E, and the paved access road. Decommissioning of the Boulder Brush Facilities would occur at the end of the Campo Lease and any renewal extension. Decommissioning of the Off-Reservation gen-tie line and high-voltage substation within the Boulder Brush Corridor would minimize new site disturbance and removal of native vegetation to the extent practicable. To the extent practicable, topsoil removed during decommissioning would be stockpiled and used as topsoil during ~~restoration~~ revegetation efforts. Soil would be stabilized and revegetated with plant species characteristic of native species within adjacent habitats. Locally available seed will be used, and seed from species that are unavailable for collection would not be incorporated into the final seed palette ~~Local seed sources would be used where feasible.~~ All decommissioning activities would take place in accordance with all applicable laws, regulations, and terms of the Private Lease.

The Developer would be responsible for the decommissioning of the Campo Wind Facilities. Prior to decommissioning, a decommissioning plan will be prepared consistent with the requirements of the Campo Lease. The decommissioning plan would be implemented after the Campo Lease term. Decommissioning refers to the dismantling of Campo Wind Facilities elements and restoration of the Campo Corridor upon expiration of the Campo Lease and the operating life of the Campo Wind Facilities.

The aboveground dismantling of the turbines and permanent Met towers would take approximately 26 weeks and would include cranes, flatbed trucks, rough terrain forklifts, 12 workers, 4 vendor trucks, and approximately 390 haul trips. Pad removal would take approximately 12 weeks with 24 workers, 4 vendor trucks, and 1,125 haul trips. Demolition and removal of the O&M facility would take approximately 8 weeks and would involve 12 workers and 4 vendor trucks.

The following sequence for removal of components would be implemented at decommissioning:

1. Turbines, MET towers, gen-tie line, and collector substation would be dismantled and removed.
2. Pad-mounted transformers, if any, would be removed.
3. All turbine, MET tower, and collector substation foundations would be removed to a depth of 3 feet.
4. The Campo Corridor would be restored to the condition required by the Campo Lease.

Turbines would be refurbished and sold or recycled as scrap material. All material that could not be salvaged would be appropriately disposed of at an authorized site in accordance with applicable laws and regulations. Reclamation of the Campo Corridor following decommissioning would be based on the terms of the Campo Lease and may include regrading, replacement of topsoil, and revegetation.

Decommissioning of the Campo Wind Facilities would minimize new site disturbance and removal of native vegetation to the extent practicable. To the extent practicable, topsoil removed during decommissioning would be stockpiled and used as topsoil during ~~restoration~~ revegetation efforts. Soil would be stabilized and revegetated with plant species characteristic of native species within adjacent habitats. Locally available seed will be used, and seed from species that are unavailable for collection would not be incorporated into the final seed palette. ~~Local seed sources would be used where feasible.~~

1.2.3 Safety Requirements

During all phases of the Project (i.e., construction and operation), the Developer and the Boulder Brush Developer would comply with OSHA standards that would allow for worker and public safety and the avoidance or minimization of environmental impacts. Construction and operation workers on the Project Site would be subject to risks of potential injuries and fatalities from physical hazards. While such occupational hazards can be minimized when workers adhere to safety standards and use appropriate protective equipment, fatalities and injuries from on-the-job accidents can still occur. An Environmental Health and Safety Plan would be developed to protect both workers and the general public during construction, operations, and decommissioning of the Project.

The plan identifies all applicable federal and state occupational safety standards, including the following:

- Safe work practices for each task (e.g., requirements for personal protective equipment and safety harnesses)
- Measures for reducing occupational electromagnetic field exposure
- Fire safety evacuation procedures
- Safety performance standards (e.g., electrical system standards and lightning protection standards)
- Hazard training and protocols for reporting serious accidents to appropriate agencies
- Inspection of vehicle and equipment for unanticipated leaks on Project right-of-way

1.2.4 Construction Traffic Control Plan

A construction Traffic Control Plan would be developed for the Project that addresses the following:

- Installation of speed limit signs along Ribbonwood Road, Crestwood Road, BIA 10/ Church Road and on-site access roads to reduce fugitive dust and adverse effects on existing site resources
- Road slope, widths, turning radii, road surface, and temporary stabilization provisions
- Number of vehicles traveling on-site per day, the size and type of vehicles, vehicle origin and destination to and from the site, and any congestion points on secondary roads
- Transport of turbine components, main assembly cranes, and other large pieces of equipment
- Specific object sizes, weights, and unique handling requirements
- An evaluation of alternative transportation approaches
- Process for complying with state requirements and for obtaining necessary permits
- Number to call to receive information regarding material deliveries and construction traffic conditions

1.2.5 Construction Waste and Hazardous Materials

Construction wastes would consist primarily of wood forms used for concrete pad construction and scrap metal steel from turbine construction. Additional wastes may include erosion control materials, such as straw bales and silt fencing, temporary fencing and/or flagging, and packaging materials from component parts and other electrical equipment. Construction wastewater would be generated from concrete trucks after concrete loads have been emptied. The construction contractor would be responsible for conducting wash-down activities, as appropriate. Portable toilets would be provided for on-site waste handling during construction and would be pumped and cleaned regularly by the construction contractor and disposed off-site in accordance with applicable regulatory requirements. No other wastewater would be generated during construction.

Construction waste would be minimized by estimating materials needs in advance and through efficient construction practices. Construction wastes would be recycled when feasible. Steel scrap would be collected and transported to a recycling facility. Wood waste would also be recycled where feasible, depending on size and quantity of scrap and leftover materials. Concrete waste would be used on-site as fill or at another site. If there is no reuse option available for concrete waste, it would be removed to a nearby landfill. Packaging waste (such as paper and cardboard) would be separated and recycled. Any non-recyclable wastes would be collected and transported to a local landfill.

Industrial wastes that may be generated in the construction phase would include paints and solvents associated with the assembly of the turbines. The Project would not include the demolition of any existing building that may contain asbestos or lead-based paint.

A Spill Prevention, Control, and Countermeasure Plan would be prepared that identifies where construction equipment fuels and wastes would be stored on site, spill prevention measures to be implemented, training requirements, appropriate spill response actions for each material or waste, the locations of spill response kits on site, a procedure for ensuring that the spill response kits are adequately stocked at all times, and procedures for making timely notifications to authorities.

Additionally, a Hazardous Materials Business Plan would be prepared that addresses storage, use, transportation, and disposal of each hazardous material anticipated to be used at the Project Site. The plan would establish the following:

- Inspection procedures
- Storage requirements
- Storage quantity limits
- Inventory control
- Nonhazardous product substitutes
- Disposition of excess materials

The Hazardous Materials Business Plan would also identify requirements for notices to federal and local emergency response authorities, as well as emergency response plans.

1.2.6 Soil Stabilization

To minimize erosion during and after construction, standard BMPs for erosion and sediment control would be implemented including but not limited to preservation of existing vegetation, hydroseeding, application of bonded fiber matrix, erosion control blankets, silt fences, fiber rolls, gravel and sand bags, and lot perimeter protection detail. In order to reduce fugitive dust and erosion, the disturbed areas on the Project Site would either be treated in one of the following methods or a combination of both: treatment with a permeable nontoxic soil binding agent, and/or placement of decomposed granite or other base material.

1.2.7 Site Revegetation and Noxious Weeds/Invasive Species Control

A Revegetation Plan would be prepared for the Boulder Brush Facilities to minimize or mitigate impacts to plants and wildlife due to construction activities. After construction is complete, the Boulder Brush Developer would work to restore native vegetation to pre-construction conditions,

as feasible, for temporary disturbance areas. Topsoil from excavations and construction activities would be segregated from sub-soil and reapplied to the surface of the ground during reclamation. To reestablish plant communities of most value to wildlife, the appropriate weed-free native grasses, forbs, and shrubs would be used. Reclamation activities on temporary disturbance areas would be undertaken as early as immediately following construction. The Revegetation Plan addresses monitoring and educating personnel on weed identification and methods for avoiding and treating infestations during construction and operation of the Boulder Brush Facilities. Personnel education regarding ~~restoration~~ revegetation would be included as part of the Worker Environmental Awareness Program training. If trucks and construction equipment arrive from locations with known invasive vegetation problems, a controlled inspection and cleaning area would be established to visually inspect construction equipment arriving to the Project Site and to remove and collect seeds that may adhere to tires and other equipment surfaces.

1.2.8 Facility Testing and Commissioning

As facilities are constructed, commissioning would take place to ensure all facilities are operating per applicable specifications. The first component to be commissioned would be the interconnection facilities (switchyard) within the Boulder Brush Corridor. Following energization and testing of those facilities, the high-voltage substation within the Boulder Brush Corridor and collector substation equipment within the Campo Corridor would be energized and tested. Interconnection, transmission, collector substation, and high-voltage substation commissioning activities could take up to a month and require detailed coordination with the utility, construction contractor, and owner. Following successful commissioning of the substations, each collection circuit would be energized and tested, and then power would become available to each wind turbine located within the Campo Corridor, to commence commissioning activities. It would take approximately 2 to 5 days to commission a wind turbine and is somewhat dependent on wind. Each wind turbine would be tested and commissioned individually along with associated equipment such as external pad-mounted transformers, if any, and the turbine control system. During these commissioning activities, test power would be delivered to Sunrise Powerlink. Following turbine commissioning, the plant SCADA system that would collect data from the MET towers within the Campo Corridor would be commissioned and tested. Upon all inspections being completed and certifications being provided by third-party inspectors, the Project would be fully operational.

1.2.9 Fire Protection

There are several fire stations near the Project Site, which include San Diego County Fire Authority, CAL FIRE, and U.S. Forest Service fire stations. The Boulevard area is serviced by the Boulevard Fire Station (Station 47), which is operated by CAL FIRE (see Figure 1-11, Fire Stations). CAL FIRE staffs the station with full-time 24/7 career firefighters through an Amador contract (staffing continues through the “off season” with the County) under which the County

funds CAL FIRE presence during this period. The primary responsibility of the CAL FIRE is wildfire protection. CAL FIRE, in association with the California Department of Corrections and Rehabilitation, also jointly manages McCain Valley Camp (male fire crews) and provides inmates with a limited level of training in fire safety and suppression techniques. Crew levels at the camp fluctuate and the response is typically for wildland fire, flood control, and community projects.

Consistent with County requirements for discretionary approvals for projects in wildland/urban interface areas, a Fire Protection Plan (Appendix I of this EIR) was prepared for the Boulder Brush Facilities. Fire prevention measures include but are not limited to the following:

- Fuel modification zones throughout the Boulder Brush Corridor for gen-tie transmission line poles, high-voltage substation, switchyard, and roads
- Portable CO₂ fire extinguishers mounted at voltage transformer units, located within the fence line of the high-voltage substation.
- Three 10,000-gallon water tanks near the high-voltage substation dedicated for firefighting purposes
- System contact information with local fire agencies/stations to assist responding firefighters during an emergency
- Consistent placarding and labeling of all components for fire safety/response

A Construction Fire Protection Plan for the Boulder Brush Facilities has also been prepared and includes measures to reduce fire risk (Appendix I). The Construction Fire Protection Plan provides various measures, including minimizing combustible and flammable materials, maintaining evacuation routes, ensuring on-site water trucks, a fire watch monitor, training of construction personnel by another entity certified to conduct such training on the proper use of firefighting equipment to fight incipient fires, and equipping all vehicles with appropriate fire extinguishers.

In addition, a fire protection plan prepared to the satisfaction of the Campo Reservation Fire Protection District and CAL FIRE would be required for implementation of the Campo Wind Facilities. The fire protection plan for the Campo Wind Facilities would include design features and risk management measures to minimize fire risk.

1.2.10 Technical, Economical, Environmental Characteristics

The following provides a discussion of the Project's technical, economic, and environmental characteristics.

1.2.10.1 Technical Considerations

The Campo Wind Facilities wind turbines would be arranged in rows in accordance with applicable industry siting recommendations for optimum energy production and minimal land

disturbance. The proposed turbine layout is shown in Figure 1-3. Typically, individual turbines are spaced approximately 1.2 to 2.0 rotor diameters apart within rows, while the rows are spaced 8 to 10 rotor diameters apart to optimize wind energy generation.

The On-Reservation and Off-Reservation gen-tie line pole structures would be spaced approximately every 500 feet and have been sited to reduce turns, which decreased construction disturbance, and to avoid tower locations in sensitive resource areas such as wetlands and cultural resources. The high-voltage substation and the switchyard have been located as close as is practicable to the point of interconnection (Sunrise Powerlink) to minimize the length of the 500 kV incoming and outgoing transmission connection line that would be constructed by SDG&E.

1.2.10.2 Economic Considerations

The Project would help facilitate the development of a local renewable energy supply, thereby improving the reliability of electrical energy production in the San Diego region by increasing local sources of electricity rather than increasing electrical energy import. The Project would also assist the State of California in meeting its Renewable Portfolio Standard by 2030, which was put in place by Senate Bill 350, known as the Clean Energy and Pollution Reduction Act of 2015. It would also assist the state in meeting its 100% zero carbon energy goal by 2045 as put in place by Senate Bill 100.

Additionally, the Project could help the County meet the goal of achieving 90% renewable electricity for the unincorporated County by 2030, which was established in the Climate Action Plan as Measure E-2.1. The Project would assist in achieving the state's zero-carbon energy and GHG emissions reduction objectives by connecting approximately 252 MW of California Renewable Portfolio Standard-qualified wind energy. The Project would generate and transmit up to approximately 252 MW of renewable wind energy that would indirectly reduce the need for new non-renewable resources (e.g., natural gas and other fossil fuels), to provide the same levels of energy and reduce GHG emissions and other criteria air pollutant emissions, associated with such non-renewable resources while minimizing impacts to natural resources.

Wind energy and other renewable energy sources are critical for meeting California's Renewable Portfolio Standards and GHG reductions. In addition to helping the nation, state, and utilities meet their renewable energy goals, the Project would provide economic activity from construction and operation of the Project. Furthermore, the Project would result in long-term revenue for the Tribe. The leasing of tribal trust lands furthers tribal interests, including economic development, revenue, and tribal governance. Approval of the proposed lease would satisfy several needs/interests, including improving the economic conditions of the Tribe through lease revenue and job creation, and utilizing the renewable energy resource.

1.2.10.3 Environmental Considerations

Wind energy can provide a number of environmental benefits, such as reductions in air and water pollution and GHG emissions compared to other sources of energy. However, wind technology, like other energy technologies, has environmental impacts. The sections outlined below, and found in Chapter 2 of this EIR, address environmental issue areas that have been found to be significant.

Aesthetics

Impacts associated with visual character or quality are often a factor with wind energy projects due to the contrast with existing visual elements of an area. Installation of Project facilities would result in the removal of rock outcrops and oak trees, altering the existing openness of the landscape and quality of existing views. Additionally, due to the visibility of Project facilities, the proximity to select public roads in the surrounding area, and the availability of open and unencumbered views of the landscape from these roadways, introduction of the Project would alter existing views available from I-8, Ribbonwood Road, McCain Valley Road, and Old Highway 80. Section 2.1, Aesthetics, of this EIR evaluates the potential changes to the existing aesthetic and visual characteristics of the Project Area and provides mitigation to reduce impacts associated with visual resources.

Air Quality

During Project construction, diesel particulate matter emissions would be emitted from construction equipment and heavy-duty trucks. In addition, there would be toxic air contaminant emissions within the fugitive dust generated by various sources (rock crushing, concrete batch plant, vehicle traffic, and blasting). Construction of cumulative projects simultaneously with the Project would result in a temporary addition of pollutants to the local airshed caused by off-road construction equipment, soil disturbance, architectural coating and asphalt pavement VOC off-gassing, on-road haul trucks, vendor trucks, and worker vehicle trips. Section 2.2, Air Quality, of this EIR analyzes potential impacts to air quality as a result of Project implementation, and provides mitigation to reduce emissions generated by the Project.

Biological Resources

Resources within the Project Area and Project Vicinity including special-status plant and wildlife species, riparian habitat, jurisdictional wetlands and waterways, and wildlife movement and nursery sites would be impacted as a result of Project implementation. Section 2.3, Biological Resources, of this EIR analyzes potential impacts relating to biological resources resulting from construction and operation of the Project and provides mitigation to reduce impacts to biological resources as a result of the Project.

Cultural Resources and Tribal Cultural Resources

Development activities as a result of the Project could affect cultural resources, tribal cultural resources, and undiscovered human remains within the Project Site. Section 2.4, Cultural Resources, and Section 2.7, Tribal Cultural Resources, of this EIR analyze potential impacts to cultural and tribal cultural resources as a result of the Project within the Project Area, including off-site improvement areas. Mitigation is provided to reduce the potential for impacts to occur as a result of Project implementation.

Hazards and Hazardous Materials

If a spill or unauthorized release of hazardous materials were to occur on the Project Site, the Project could potentially expose people to hazardous materials. Additionally, during construction, operation, and decommissioning of the Project, there would be increased human activity and ignition sources, including equipment that could create spark, be a source of heat, or leak flammable materials on the Project Site. Section 2.5, Hazards and Hazardous Materials, of this EIR analyzes potential impacts relating to hazards and hazardous materials resulting from implementation of the Project. Mitigation is provided to reduce impacts associated with the handling and/or accidental release of hazardous materials, as well as the possibility of wildland fires.

Noise

Noise as a result of Project implementation would generate noise levels in exceedance of applicable standards and guidelines. Section 2.6, Noise, of this EIR evaluates noise and vibration impacts resulting from implementation of the Project. Mitigation measures are provided to reduce impacts associated with noise.

Traffic and Transportation

The Project would require the use of construction trucks to transport equipment and materials during construction activities. Section 2.8, Traffic and Transportation, of this EIR analyzes potential traffic-related impacts as a result of the Project.

Wildfire Hazards

The Project is located in a Very High Fire Hazard Severity Zone (CAL FIRE 2007) and could impact the public and environment by exposure to wildfire due to installation of wind energy generation facilities and associated infrastructure. Project impacts related to wildfire risk and proposed mitigation to reduce impacts associated with the possibility of wildfires is discussed in detail in Section 2.9, Wildfire, of this EIR.

Other Environmental Considerations

Groundwater Supply

Due to the intermittent flow of surface water within the Project Area during most of the year and the unavailability of imported water, domestic water usage is almost entirely dependent upon groundwater supplies. Consequently, preservation of groundwater levels and quality is vital when evaluating proposed land uses within the Project Area. Section 3.1.5, Hydrology and Water Quality, analyzes Project groundwater demand, groundwater availability, and potential impacts to water quality.

1.3 Project Location

The Project would be located in southeastern San Diego County (see Figure 1-1, Project Location). The Project consists of both the Campo Wind Facilities that would be located on Reservation land leased from the Tribe and the Boulder Brush Facilities that would be located on adjacent land to the northeast of the Reservation leased from a private landowner. The Project Site totals approximately 2,520 acres, which includes approximately 2,200 acres of land within the Reservation (Campo Corridor) and 320 acres on private lands (Boulder Brush Corridor). Land ownership surrounding the Project Area consists of a mixture of private, State of California, Bureau of Land Management, and tribal lands.

In the Project Vicinity, Community Plan areas (designated by the County's General Plan) include the Pine Valley Community Plan area, the Campo/Lake Morena Community Plan area, the Boulevard Subregional Planning Area, and the Mountain Empire Subregional Planning area. Figure 3.1.6-1, Existing Land Use Designations, in Section 3.1.6, Land Use and Planning, of this EIR depicts the surrounding Community Plans in relation to the Project Area. Project consistency with applicable plans is discussed in detail in Section 3.1.6.

Boulder Brush Facilities

The Boulder Brush Facilities would be located on private land in the McCain Valley area of the unincorporated County, north of the community of Boulevard and I-8 (see Figure 1-2 and Table 1-2, Assessor's Parcel Numbers within Boulder Brush Boundary). Regional access is provided by I-8. Local access is provided by Ribbonwood Road.

Land within the 2,000-acre Boulder Brush Boundary currently consists of largely undeveloped ranch land, a portion of which had been used for cattle grazing in the past. There is evidence of off-highway vehicle activity within the Boulder Brush Boundary. Numerous "No Trespassing" signs have been posted at locations along the Boulder Brush Boundary to deter off-highway vehicle use by the public. The 500 kV Sunrise Powerlink traverses the northeast

portion of the Boulder Brush Boundary, and the existing Kumeyaay Wind and Tule Wind facilities are located to the west and northeast, respectively. In addition, several rural residential homes are located to the south.

The Boulder Brush Facilities would be located within a 320-acre corridor (Boulder Brush Corridor) within the Boulder Brush Boundary. The total disturbed area within the Boulder Brush Corridor would be approximately 131 acres.

Campo Wind Facilities

The Campo Wind Facilities would be located on lease lands within the 16,000-acre Reservation. The Campo Wind Facilities are proposed within an approximately 2,200-acre corridor (Camp Corridor) on the Reservation. The area of disturbance within the Camp Corridor would be approximately 800 acres. The Reservation extends from the United States/Mexico international border to north of I-8. Regional access is provided by I-8, and local access is provided by Crestwood Road, BIA 10/Church Road.

The Reservation is surrounded by open space and rural residential developments in unincorporated communities. The Manzanita Reservation borders the northern portion of the Reservation and the La Posta Reservation is located to the northwest.

1.4 Environmental Setting

The following description of the environmental setting provides a general overview of the Project Area. More detailed descriptions of the environmental setting as it relates to each environmental issue area are provided in the individual sections of this EIR.

The Project Site lies between two major drainage divides: the Tecate Divide to the west, and the In-Ko-Pah Mountains to the east. This area occurs within the Live Oak Springs U.S. Geological Survey topographic quadrangle.

Boulder Brush Facilities

Land within the Boulder Brush Boundary is characterized by sparsely developed, high-desert rolling hills and surrounded, in part, by rural single-family residences, large-lot ranches, renewable energy and transmission infrastructure. The elevation ranges from approximately 3,280 feet above mean sea level (amsl) to approximately 4,120 feet amsl.

There are no existing or currently proposed residential uses within the Boulder Brush Boundary. Existing rural residences are located to the south of the Boulder Brush Boundary. The community of Boulevard, to the south of I-8, is located approximately 3.5 miles south of the Boulder Brush Boundary.

Native vegetation communities within the Boulder Brush Boundary consist of montane buckwheat scrub, big sagebrush scrub, granitic northern mixed chaparral, granitic chamise chaparral, red shank chaparral, semi-desert chaparral, wildflower field, emergent wetland, southern arroyo willow riparian forest, and coast live oak woodland (including open coast live oak woodland). The terrain in the area ranges from valley bottoms to house-sized boulder-covered ridgelines.

As previously described, there is evidence of off-highway vehicle activity within the Boulder Brush Boundary. Numerous “No Trespassing” signs have been posted at locations along the Boulder Brush Boundary to deter off-highway vehicle use by the public. The Bureau of Land Management-managed McCain Valley Recreation Management Zone is located directly north of the Boulder Brush Boundary. Off-highway vehicle use is considered a primary activity in the McCain Valley Recreation Management Zone, as identified in the Eastern San Diego County Resource Management Plan.

Campo Wind Facilities

Terrain within the Reservation is characterized by sparsely developed, high-desert rolling hills interspersed with renewable energy and transmission infrastructure. The elevation ranges from approximately 3,100 feet amsl to approximately 4,200 feet amsl.

The Reservation is in a desert transition zone, which supports a variety of habitat types and vegetation communities and is dominated by chamise chaparral with both a monotypic phase and a mixed chaparral phase. Additional vegetation communities found throughout this area and especially along ridges and slopes include red shank chaparral, big sagebrush scrub, and upper Sonoran subshrub scrub. A series of ridges running north to south is located throughout the Reservation separated by shallow valleys consisting of coast live oak woodland, nonnative grassland, and southern willow scrub vegetation. Various large rock-outcrops of light-colored boulders are scattered throughout this area but are primarily located along the ridgelines.

The Reservation includes scattered housing and some moderate development near the Tribal Administration Center, the Southern Indian Health Center Clinic, the current Campo Materials sand-mining operation, and the Golden Acorn Casino. Three highways cross the region: I-8, Old Highway 80, and State Route 94. San Diego Metropolitan Transit Service owns and operates the Desert Line railway that extends north and east from the U.S./Mexico border to Plaster City in Imperial County, where it joins the Union Pacific Railroad Line from El Centro. The rail line runs south of the Project Site.

Uses within the Reservation include rural residential, wind energy facilities, the Golden Acorn Casino, Tribal facilities, and Campo Materials aggregate activities. The Campo Corridor does not directly include these uses, although portions of the Campo Corridor are adjacent to these uses.

1.5 Intended Uses of the EIR

This EIR is an informational document that will inform public agency decision makers and the public generally about the significant environmental effects of the Project, identify possible ways to minimize the significant effects, and describe reasonable alternatives to the portions of the Project under County land use and permitting jurisdiction (i.e., the Boulder Brush Facilities). This EIR has been prepared in accordance with the requirements of the County of San Diego Environmental Impact Report Format and General Content Requirements (County of San Diego 2006) and CEQA statute and guidelines (California Public Resources Code, Section 21000 et seq.; 14 CCR 15000 et seq.). The Notice of Preparation (NOP) for the EIR was released for public review on February 14, 2019, and associated comment letters received during the public review period are included as Appendix A to this EIR. The Initial Study prepared for the Boulder Brush Facilities is also included in Appendix A. This EIR addresses issues identified in the Initial Study and comments received regarding the NOP.

This EIR will be made available for review for members of the public and public agencies for 45 days to provide comments “on the sufficiency of the document in identifying and analyzing the possible impacts on the environment and ways in which the significant effects of the Project might be avoided or mitigated” as stated in the CEQA Guidelines, Section 15204 (14 CCR 15000 et seq.).

As the designated lead CEQA agency, the County is responsible for preparing this document. The decision to approve one or more MUPs for the Boulder Brush Facilities is within the purview of the County Planning Commission and the Board of Supervisors. When deciding whether to approve one or more MUPs for the Boulder Brush Facilities, the County will use the information included in this EIR to consider potential impacts on the physical environment associated with the Project.

The County will consider written comments received on the EIR in making its decision whether to certify the EIR as complete and in compliance with CEQA, and also whether to approve or deny the Boulder Brush Facilities. Environmental considerations and economic and social factors may be weighed to determine the most appropriate course of action. If the EIR is certified and the Boulder Brush Facilities are approved, state or local agencies with permitting authority over all or portions of the Project may use the EIR as the basis for their evaluation of environmental effects of the Project under CEQA and approval or denial of applicable permits.

1.5.1 Project Approvals/Permits

The Project requires approvals by BIA and the County. In addition, permits may be required by other state and federal agencies. Table 1-3, Possible Authorizations, Permits, Reviews, and Approvals, includes discretionary approvals/permits that may be obtained during the decision-making process. The table is organized by agency/jurisdiction. In the case where multiple

discretionary approvals/permits are necessary from a single agency, the approvals are listed in the order they are believed to occur.

The Campo Wind Facilities are subject to lease approval by BIA and subject to environmental review under NEPA with BIA as the Lead Agency and the County as a cooperating agency. BIA released a Notice of Intent to prepare an EIS on November 21, 2018, and closed the comment period on December 21, 2018. BIA held a public scoping meeting on December 6, 2018, at the Tribal Hall on the Reservation.

The Boulder Brush Facilities are subject to the land use jurisdiction of the County. Permits that would be required to implement the Boulder Brush Facilities include a MUP, building permit, grading permit, County Right-of-Way permit, and various administrative permits as described below.

Major Use Permit. The Boulder Brush Facilities are considered a Major Impact Service and Utility type of use that requires approval of a MUP. The land within the Boulder Brush Boundary has a zone classification of S92. An MUP application would be processed according to Section 7350 of the Zoning Ordinance, including making required findings pursuant to Section ~~7359~~7358.

Building Permits. The building of structures on private lands would require a building permit from the County. Although this is a ministerial permit, the applicant must adhere to all applicable regulations. Exact requirements for building permits are dependent upon the type of structure proposed.

Grading Permits. The County Grading, Clearing, and Watercourses Ordinance (Grading Ordinance) is contained in Title 8, Division 7, of the Code of Regulatory Ordinances. The Project involves grading, clearing, and removal of natural vegetation and therefore requires a grading permit from the County for activities on private land. Proposed grading activities must meet requirements of the County's Grading Ordinance.

In addition to the BIA lease approval and County permit approvals, other federal, state, and local agencies require approvals for the construction of the Project. County and state permits would be required for transportation and road use during construction. Permits from the U.S. Army Corps of Engineers, California Department of Fish and Wildlife, and Regional Water Quality Control Board may be needed. Table 1-3 identifies the permits, authorizations, reviews, and/or approvals that may be needed for the Project. Other local and state agencies may rely on this EIR in approving any discretionary permits required for the Project as set forth in Table 1-3.

1.5.2 Related Environmental Review and Consultation Requirements

Pursuant to the CEQA Guidelines (Section 15365), the County prepared an NOP for this EIR. The NOP was publicly circulated for 30 days beginning February 14, 2019. The County held a public scoping meeting on February 28, 2019, at the Boulevard Fire Station to provide responsible agencies and members of the public with information about the CEQA process and to provide further opportunities to identify environmental issues and alternatives for consideration in the EIR. Public comments received during the NOP scoping process are provided in Appendix A.

This EIR also incorporates by reference the County of San Diego Wind Energy Ordinance Amendment POD 10-007 EIR, which was approved on October 31, 2012 (SCH No. 2010091030). This document can be viewed online and in person at the County of San Diego Planning and Development Services.

1.6 Project Inconsistencies with Applicable Regional and General Plans

Planning documents reviewed for the Boulder Brush Facilities include the County's General Plan and Mountain Empire Sub-Regional Plan. Other planning documents reviewed for the Project include the Regional Air Quality Strategy for the San Diego County Air Pollution Control District, the Regional Water Quality Control Board (Region 9, San Diego, and Region 7, Colorado River) Basin Plans, and the County of San Diego Multiple Species Conservation Program. In addition, the Draft Conservation Strategy for the future Multiple Species Conservation Program Plan has been reviewed.

The Campo Wind Facilities are subject to federal and Tribal law. The Reservation is not under the jurisdiction of the State of California or the County. The Tribe's land use and environmental regulations include the CEPA statutes, the Campo Land Use Code, and the Campo Land Use Plan. However, under the Campo Lease, the Campo Wind Facilities are not required to comply with the Campo Land Use Code or the Campo Land Use Plan. Project consistency with applicable plans is discussed and analyzed in Section 3.1.6, Land Use and Planning, of this EIR.

1.7 List of Past, Present, and Reasonably Anticipated Future Projects in the Project Area

CEQA Guidelines, Section 15355, defines cumulative effects as two or more individual effects, which, when considered together, are considerable or which compound or increase other environmental impacts. The CEQA Guidelines further state that individual effects may include changes resulting from a single project or a number of separate projects, or the incremental impact of the project when added to other closely related past, present, and reasonably foreseeable future projects. CEQA Guidelines, Section 15130, allows for the use of two alternative methods to determine the scope of projects to analyze cumulative impacts.

List Method: A list of past, present, and probable future projects producing related or cumulative impacts, including, if necessary, those projects outside the control of the agency.

General Plan Projection Method: A summary of projects contained in an adopted general plan or related planning document, or in a prior environmental document, that have been adopted or certified, which describe or evaluate regional or area-wide conditions contributing to the cumulative impact.

The cumulative analysis conducted for this EIR is based on both the list method and summary of projections method. The summary of projections method uses the County's General Plan and Mountain Empire Subregional Plan (both of which are available at the following website: <http://www.sandiegocounty.gov/pds/generalplan.html>); the summary project method was used in Section 2.2, Air Quality, and Section 3.1.5, Hydrology and Water Quality. Each environmental issue area within this EIR includes a discussion of potential cumulative impacts based on these methods. Table 1-4, Cumulative – Reasonably Foreseeable, Approved, and Pending Projects, lists projects that serve as the foundation on which the cumulative analysis approach has been based. These projects are also illustrated in Figure 1-12, Cumulative Projects.

1.8 Growth-Inducing Impacts

CEQA requires a discussion of the ways in which a proposed project could induce growth. Growth-inducing impacts are those that foster economic or population growth or the construction of new development, either directly or indirectly, in the surrounding environment. In addition, the potential for characteristics of the project to encourage or facilitate additional growth that could significantly affect the environment, either individually or cumulatively, must be considered.

During construction, the Project would employ a total of approximately 684 workers, with a daily maximum of 561 workers at the peak of construction and an average daily peak of 202 workers. These workers are not anticipated to relocate to the area with their families and are not expected to induce substantial population growth in the Mountain Empire and Boulevard areas. It is anticipated that workers from San Diego to the west or Imperial Valley to the east would construct the Project. During operation, the Project would employ 10 to 12 on-site workers for the O&M facility on the Reservation. This number of permanent workers is not considered a substantial increase in population growth, the limited scale of wind energy facility construction and operation would not affect the employment base within the San Diego region as a whole.

Additionally, the development of the Project would not induce substantial population growth in the Mountain Empire region. The Project would not propose any physical or regulatory changes that would remove a restriction to or encourage population growth in an area, including but not limited to the following: large-scale residential development; accelerated conversion of homes to

commercial or multifamily use; regulatory changes including General Plan Amendments encouraging population growth, specific plan amendments, zone reclassifications, or sewer or water annexations; or Local Agency Formation Commission annexation actions. The Project is intended to supply clean, renewable energy to meet the demands of California consumers. The Project would supplement the region's energy supply and would not encourage housing growth or result in growth-inducing impacts.

Table 1-1
Estimated Construction Equipment and Vehicles

Construction Phase	Equipment
Clearing, grading, access road and pads construction	Dozers
	Scrapers
	Graders
	Rollers
	Rock crusher
	Water trucks
	Delivery trucks
Foundations construction	Graders
	Tractor/loader/backhoes
	Dozers
	Concrete truck pumps
	Welders
	Generator sets
	Water trucks
	Delivery trucks
Turbine installation	Cranes
	Forklifts
	Air compressors
	Welders
	Generator sets
	Delivery trucks
Gen-tie line installation	Cranes
	Forklifts
	Tractor/loader/backhoes
	Air compressors
	Welders
	Generator sets
	Delivery trucks
Underground electrical collection and communications system installation	Tractor/loader/backhoes
	Trenchers
	Rollers
	Delivery trucks
	Water trucks

**Table 1-1
Estimated Construction Equipment and Vehicles**

Construction Phase	Equipment
Collector substation	Air compressors
	Cranes
	Forklifts
	Generator sets
	Pumps
	Tractors/loaders/backhoes
	Welders
	Delivery trucks
High-voltage substation	Cranes
	Forklifts
	Tractor/loader/backhoes
	Welders
	Generator sets
	Air compressors
	Concrete truck pumps
	Delivery trucks
Switchyard	Cranes
	Forklifts
	Tractor/loader/backhoes
	Welders
	Generator sets
	Air compressors
	Concrete truck pumps
	Delivery trucks
Paving	Pavers
	Other paving equipment
	Rollers
O&M Facility	Forklifts
	Tractor/loader/backhoes
	Welders
	Generator sets
	Air compressors
	Delivery trucks
Meteorological towers	Cranes
	Forklifts
	Tractor/loader/backhoes
	Welders
	Delivery trucks

**Table 1-2
Assessor's Parcel Numbers within Boulder Brush Boundary**

Assessor's Parcel Numbers				
528-220-02	528-220-03	529-050-01	529-060-01	529-090-02
529-090-03	529-100-02	529-100-03	529-120-01	529-120-03
529-130-01	611-010-01	611-010-02	611-010-03	611-020-01
611-050-04	611-050-05	529-100-01	—	—
528-220-02	528-220-03	529-050-01	529-060-01	529-090-02
529-090-03	529-100-02	529-100-03	529-120-01	529-120-03
529-130-01	611-010-01	611-010-02	611-010-03	611-020-01
611-050-04	611-050-05	529-100-01	—	—

**Table 1-3
Possible Authorizations, Permits, Reviews, and Approvals**

Agency	Permit/Approval/Consultation
County of San Diego	Major Use Permit
	Grading Permit
	Stockpile Permit
	Building Permit
	County Right-of-Way, Construction, Excavation, and Encroachment Permits
Regional Water Quality Control Board – San Diego Region 9	NPDES Permit
	General Construction Stormwater Permit
	Section 401 Water Quality Certification/ Waste Discharge Requirements
	Wastewater Discharge Permit
BIA	NEPA Review and Lease Approval
USFWS	Section 7(a) Incidental Take Permit or Biological Opinion
CEPA	NEPA Cooperating Agency, Water Permits, Other Required Authorizations
USACE	Section 404 Dredge and Fill Authorization
CDFW	1602 Streambed Alteration Agreement, Section 2081 Incidental Take Permit
EPA	Section 401 Water Quality Certification under CWA
CSHPO	Section 106 Consultation
Caltrans	Oversized/Heavy Load Permit, Encroachment Permit
FAA	Determinations of No Hazard

Notes: NPDES = National Pollutant Discharge Elimination System; BIA = Bureau of Indian Affairs; NEPA = National Environmental Policy Act; USFWS = U.S. Fish and Wildlife Service; CEPA = Campo Environmental Protection Agency; USACE = U.S. Army Corps of Engineers; CDFW = California Department of Fish and Wildlife; EPA = U.S. Environmental Protection Agency; CWA = Clean Water Act; CSHPO = California State Historic Protection Office; Caltrans = California Department of Transportation; FAA = Federal Aviation Administration.

**Table 1-4
Cumulative – Reasonably Foreseeable, Approved, and Pending Projects**

Project	Type	Status	Distance from Project	Project-Related Impacts
ENERGIA SIERRA JUAREZ WIND PROJECT I: Development of 400 MW of wind generation. Phase I (just north of the town of La Rumorosa in Mexico) is proposed to generate approximately 100 MW of energy with 45 to 52 turbines. Point of interconnection proposed with the ECO Substation (CAISO 2010).	PF-W	C	Approx. 15 miles	Aesthetics, Air Quality, Biological Resources, Cultural Resources, and Hazards and Hazardous Materials (Fire)
TULE WIND FARM: 12,239 acres of public lands and land within County jurisdiction, 186 MW, with 57 wind turbines. The Project would deliver power through the Project substation via a 138-kilovolt (kV) transmission line to run south to an interconnection with the proposed San Diego Gas & Electric (SDG&E) Rebuilt Boulevard Substation.	PF-W	Phase 1 = C Phase 2 = A	Approx. 0.25 miles	Air Quality, Biological Resources, Cultural Resources, Public Services, and Hazards and Hazardous Materials (Fire)
OCOTILLO EXPRESS LLC, CACA 051552: Development of 562 MW wind farm on 14,691 acres in two phases.	PF-W	C	Approx. 10 miles	Aesthetics, Air Quality, Biological Resources, Cultural Resources, and Noise
ENERGIA SIERRA JUAREZ U.S. TRANSMISSION, MUP: 230 kV double circuit power lines leading to SDG&E ECO Substation near the Mexican border.	PF	C	Approx. 13 miles	Aesthetics, Air Quality, Biological Resources, Cultural Resources, and Hazards and Hazardous Materials (Fire)
ECO SUBSTATION: East County (ECO) Substation, Rebuilt Boulevard Substation, and 13.3-mile 138 kV line between Rebuilt Boulevard Substation and ECO Substation.	PF	C	Approx. 13 miles	Aesthetics, Air Quality, Biological Resources, Cultural Resources, Hydrology/Water Quality, Noise, and Hazards and Hazardous Materials (Fire)
RUGGED SOLAR: Major Use Permit Modification MUP-12-007W1, MUP-12-007TE; MUP for the construction and operation of a 74 MW solar energy system on an approximately 765-acre site.	PF-S	<u>A (original application)</u> UC <u>UR (revised application)</u>	Approx. 5 miles	Aesthetics, Air Quality, Biological Resources, Cultural Resources, Hydrology/ Water Quality, Noise, Public Services, and Hazards and Hazardous Materials (Fire)
GOLDEN ACORN CASINO AND TRAVEL CENTER: SCH No. 2007071097: 33-acre expansion consisting of 150-room hotel, 900-space parking garage, surface parking, RV park, casino expansion, bowling alley, arcade, offices, retail, restaurants/food service, wind turbines, and water and wastewater improvements in three phases.	F	C	Approx. 4 miles	Aesthetics, Air Quality, Biological Resources, Cultural Resources, Noise, Public Services, Utilities, and Hazards and Hazardous Materials (Fire)
FREEDOM RANCH: Major Use Permit; MUP 74-011W2; Expand existing facilities from 50 beds to 125 in four phases. (Alcohol/Drug Treatment and Recovery Facility)	R	A	Approx. 12 miles	Aesthetics, Air Quality, Biological Resources, Cultural Resources, Noise, Public Services, Utilities, and Hazards and Hazardous Materials (Fire)

**Table 1-4
Cumulative – Reasonably Foreseeable, Approved, and Pending Projects**

Project	Type	Status	Distance from Project	Project-Related Impacts
BOULEVARD FIRE STATION: Replaced existing fire station along Highway 94. The completed Boulevard Fire Station is 8,496 square feet including an apparatus bay, and has a total footprint of disturbance of approximately 30,000 square feet of the 17.5-acre parcel. Roadway improvements along the northern boundary and roadway access improvements to Manzanita Dulce were completed as part of this project	PF	C	Approx. 4 miles	Aesthetics and Air Quality
ROUGH ACRES FOUNDATION CAMPGROUND FACILITY; Major Use Permit; MUP-12-021; MUP for a campground/conference center. (wellness center and campground facility)	O	UR	Approx. 2 miles	Aesthetics, Air Quality, Biological Resources, Cultural Resources, Noise, Public Services, Utilities, and Hazards and Hazardous Materials (Fire)
Jacumba Community Services District (JCSD) Capacity Increase: Project would involve creation of new well at existing monitoring well site (Park Well) to increase capacity of JCSD water supply.	O	A	Approx. 11 miles	Hydrology Water Quality
JACUMBA SOLAR: Major Use Permit; MUP-14-041; MUP for the construction and operation of a 20 MW solar energy system on an approximately 304-acre site.	PF-S	C	Approx. 13 miles	Aesthetics, Air Quality, Biological Resources, Cultural Resources, Geology & Soils, Hazards & Hazardous Materials, Hydrology & Water Quality, Land Use & Planning, Noise, Public Services, Transportation/Traffic, Utilities & Service Systems
BOULEVARD SOLAR: Major Use Permit Modification: MUP-12-010W1 MUP-12-010TE; MUP for the construction and operation of a 60 MW solar energy system on an approximately 420-acre site.	PF-S	UR	Approx. 9 miles	TBD pending completion of environmental analysis
BOULEVARD ENERGY STORAGE: Minor Use Permit; ZAP-17-006; ZAP for the construction and operation of a 100 MW energy storage facility on a 2-acre footprint.	PF	UR	Approx. 6 miles	TBD pending completion of environmental analysis
JVR SOLAR: Major Pre-Application; MPA-17-016; Proposed construction and operation of a 100 MW solar energy system on an approximately 571-acre site.	PF-S	UR	Approx. 10 miles	TBD pending completion of environmental analysis
CAMERON SOLAR: Major use Permit; MUP-18-004; MUP for the construction and operation of a 1.7 MW solar energy system consisting of approximately 19 acres on a 164.7-acre parcel.	PF-S	UR	Approx. 13 miles	TBD pending completion of environmental analysis

**Table 1-4
Cumulative – Reasonably Foreseeable, Approved, and Pending Projects**

Project	Type	Status	Distance from Project	Project-Related Impacts
TORREY WIND: Construction and operation of a 126-MW wind energy generation facility consisting of 30 wind turbines on approximately 700 acres. Torrey Wind site overlaps with the proposed Boulder Brush Facilities and both would use the proposed substation and switchyard to connect to Sunrise Powerlink.	PF-W	UR	Within Boulder Brush Boundary	TBD pending completion of environmental analysis
METEOROLOGICAL TESTING FACILITIES: Administration Permit; PDS2018-AD-18-007; NOE filed for the construction and operation of meteorological testing facilities to collect wind and climate data to determine site viability for the Proposed Project, Torrey Wind.	PF	UC	On Project Site	TBD pending completion of environmental analysis
LEVEL 3 COMMUNICATIONS LLC: Minor Use Permit; PDS2001-3400-99-031; For the construction and operation of a Fiberoptic In-Line Application Facility consisting of two equipment shelters measuring 414 square feet and 286 square feet, a second facility consisting of six new shelters comprising 2520 square feet, a 255 square foot generator shelter, the relocation of an existing 255 square foot generator hut, and a 8'6" sound wall.	PF	C	Approx. 3.25 miles	Negative Declaration
SITE MASTER INC: Major Use Permit; MUP-14-005; MUP for the construction and operation of a 35-foot tall faux elevated water tank with two mounted microwave dishes.	PF	C	Approx. 3.25 miles	Notice of Exemption
PACIFIC TELEPHONE: Major Use Permit; PDS2011-3300-76-061; MUP for the construction and operation of a 64 square foot equipment shelter.	PF	C	Approx. 4.25 miles	Special Use Permit
WHITE STAR COMMUNICATIONS SITE: Major Use Permit; PDS2011-3300-88-064; MUP for the construction and operation of a radio communications facility for SAFE (San Diego Authority for Freeway Emergency) consisting of a tower max height of 70', a mounted microwave dish, and a 200 square foot equipment shelter with an antenna max height 40'.	PF	C	Approx. 4.75 miles	Negative Declaration
PACTEL WHITE STAR: Major Use Permit; MUP PDS2003-3300-90-018; MUP for the construction and operation of a 100-foot	PF	C	Approx. 4.75 miles	Negative Declaration

**Table 1-4
Cumulative – Reasonably Foreseeable, Approved, and Pending Projects**

Project	Type	Status	Distance from Project	Project-Related Impacts
lattice tower with 10-foot whip antenna on top and two buildings measuring 288 square feet and 567 square feet, a 270 square foot building, 8 panel antennas, a 6-foot dish antenna, a 159.5 square foot emergency standby generator surrounded by a 7'6" CMU block wall with roof and acoustic panel, 15 panel antennas, and a 230 square foot equipment shelter				
SD0716 MANZANITA – FWLL MODIFICATION & T-MOBILE L700: Site Plan; PDS2016-STP-16-022, PDS2014-STP-14-009, PDS2016-STP-16-020; Site Plan for the construction and operation of 8 panel antennas, 4 new RRUs (total 5), 4 RF filters, 4 TMAs, 2 surge suppressors mounted to an existing 35-foot wooden pole, 2 new equipment cabinets (total 4), and one GPS antenna (total 2).	PF	C	Approx. 2.5 miles	Notice of Exemption
VZW I-8 BOULEVARD: Site Plan; PDS2014-STP-14-011; Site Plan for the construction and operation of 12 antennas mounted to a new 35 foot faux water tank, an associated equipment shelter, and an emergency generator.	PF	A	Approx. 2.25 miles	Biological Resources, Hazards & Hazardous Materials
KUMEYAAY WIND: 50 MW, 25 wind turbine project located on Campo tribal lands.	PF-W	C	Approx. 1.3 miles	Air Quality, Biological Resources, Cultural Resources, Public Services, and Hazards and Hazardous Materials (Fire)

Notes:

PF = Public Facilities and Utilities; S = Solar; W = Wind; T = Transmission; F = Federal; R = Residential; O = Other; MUP = Major Use Permit; A = Approved; UC = under construction; UR = under review; C = Completed; kV = kilovolt; MW = megawatt; ECO = East County; TM = Tentative Map.

INTENTIONALLY LEFT BLANK

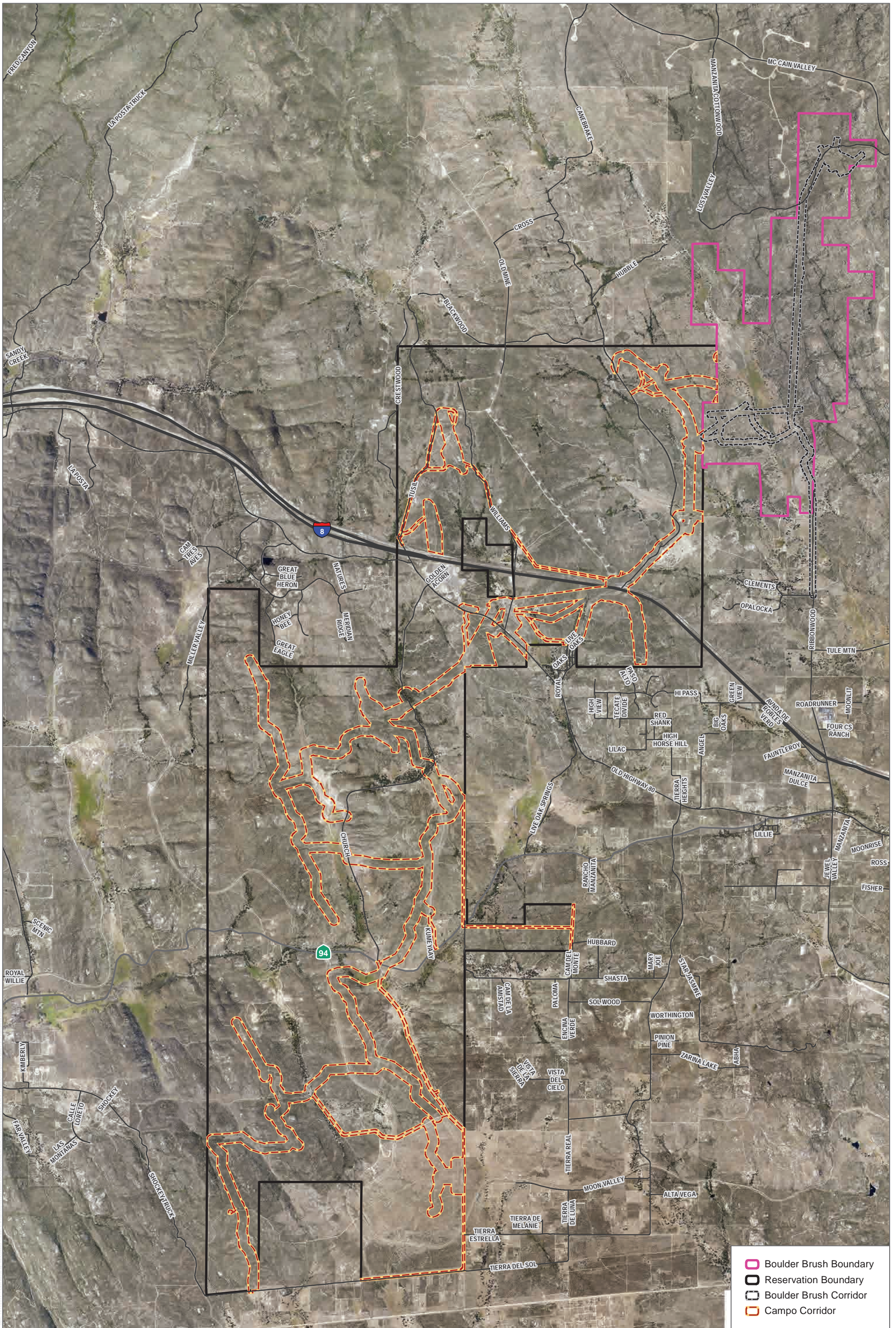

SOURCE: SANGIS 2017



FIGURE 1-2
Project Area

Campo Wind Project with Boulder Brush Facilities

INTENTIONALLY LEFT BLANK

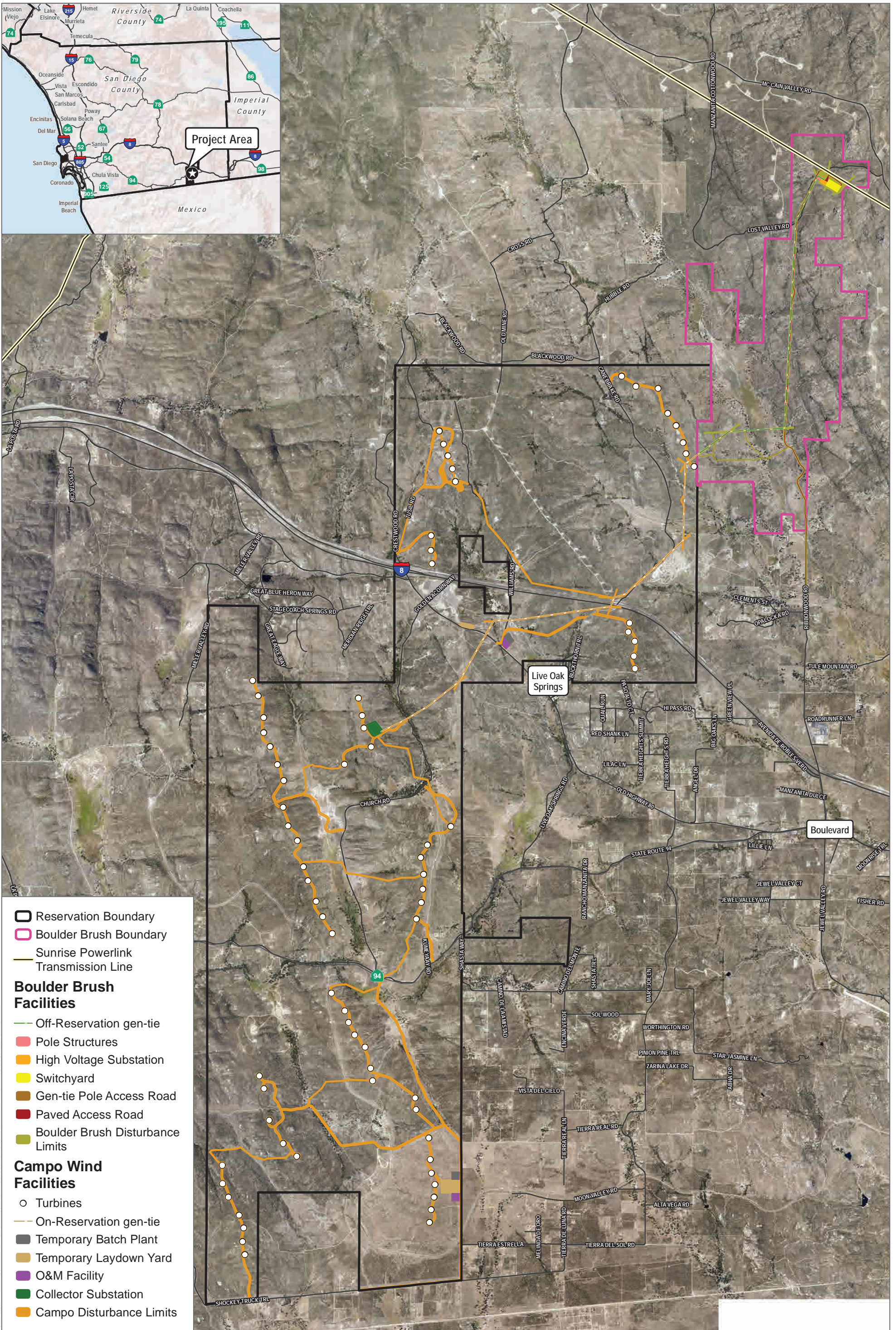

SOURCE: SANGIS 2017

NOTE: As a result of Federal Aviation Administration review, four of the 76 586-foot turbine site locations would not be utilized. These four wind turbine sites are located in the northwestern corner of the Reservation.

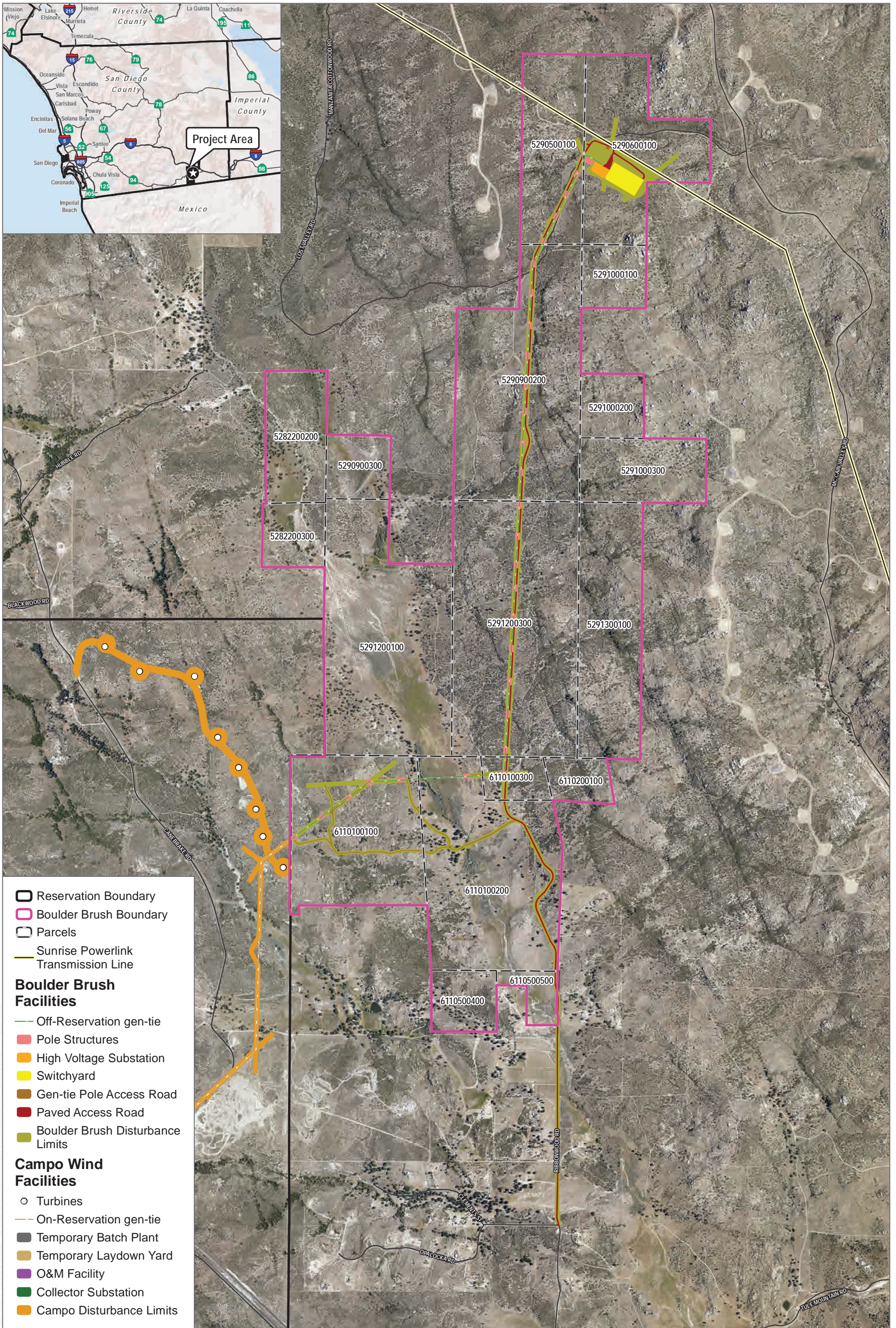

FIGURE 1-3

Project Site Plan

Campo Wind Project with Boulder Brush Facilities

INTENTIONALLY LEFT BLANK



SOURCE: SANGIS 2017, 2019



FIGURE 1-4
Boulder Brush Site Plan
 Campo Wind Project with Boulder Brush Facilities

INTENTIONALLY LEFT BLANK

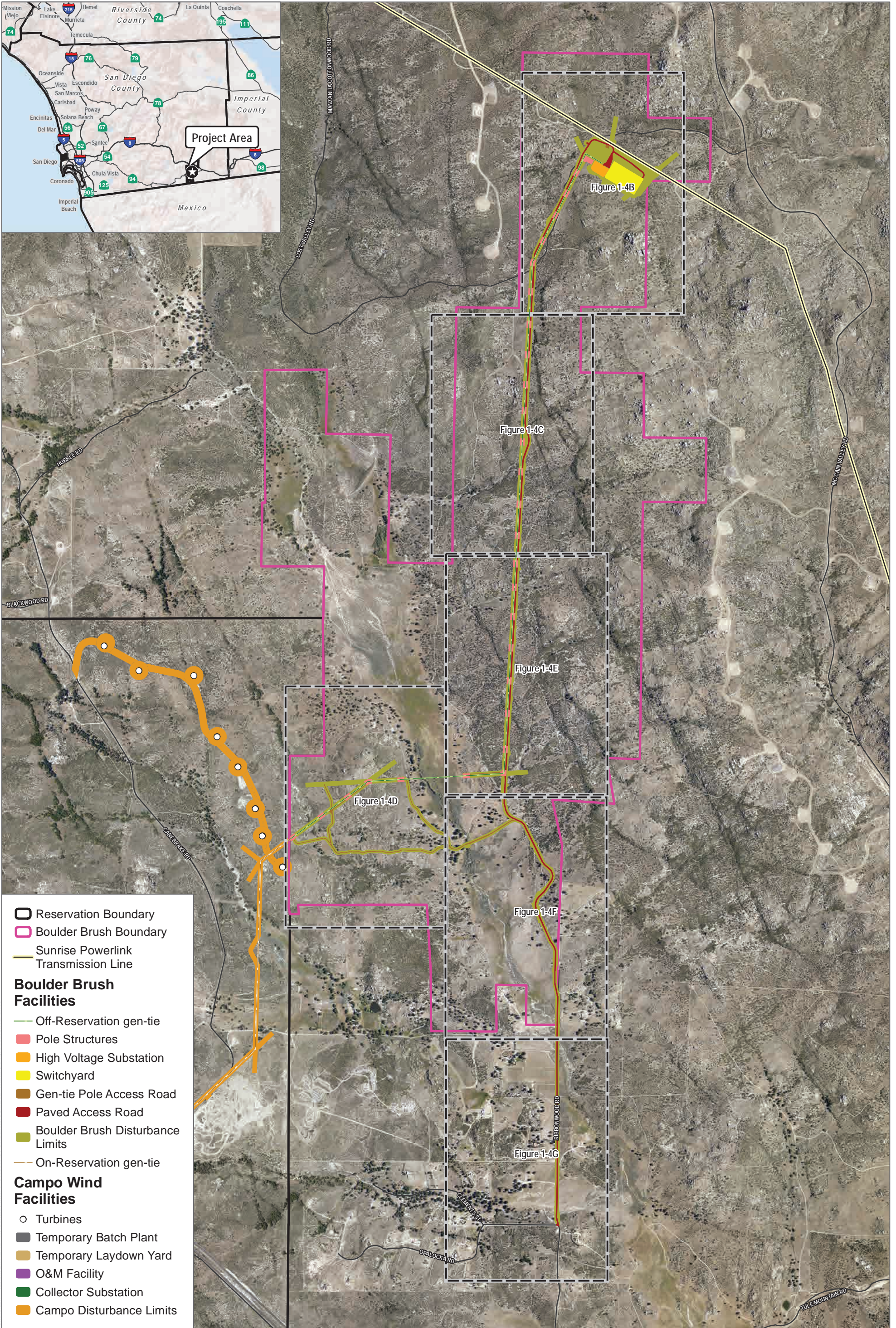

- Reservation Boundary
 - Boulder Brush Boundary
 - Sunrise Powerlink Transmission Line
- Boulder Brush Facilities**
- Off-Reservation gen-tie
 - Pole Structures
 - High Voltage Substation
 - Switchyard
 - Gen-tie Pole Access Road
 - Paved Access Road
 - Boulder Brush Disturbance Limits
 - On-Reservation gen-tie
- Campo Wind Facilities**
- Turbines
 - Temporary Batch Plant
 - Temporary Laydown Yard
 - O&M Facility
 - Collector Substation
 - Campo Disturbance Limits

SOURCE: SANGIS 2017

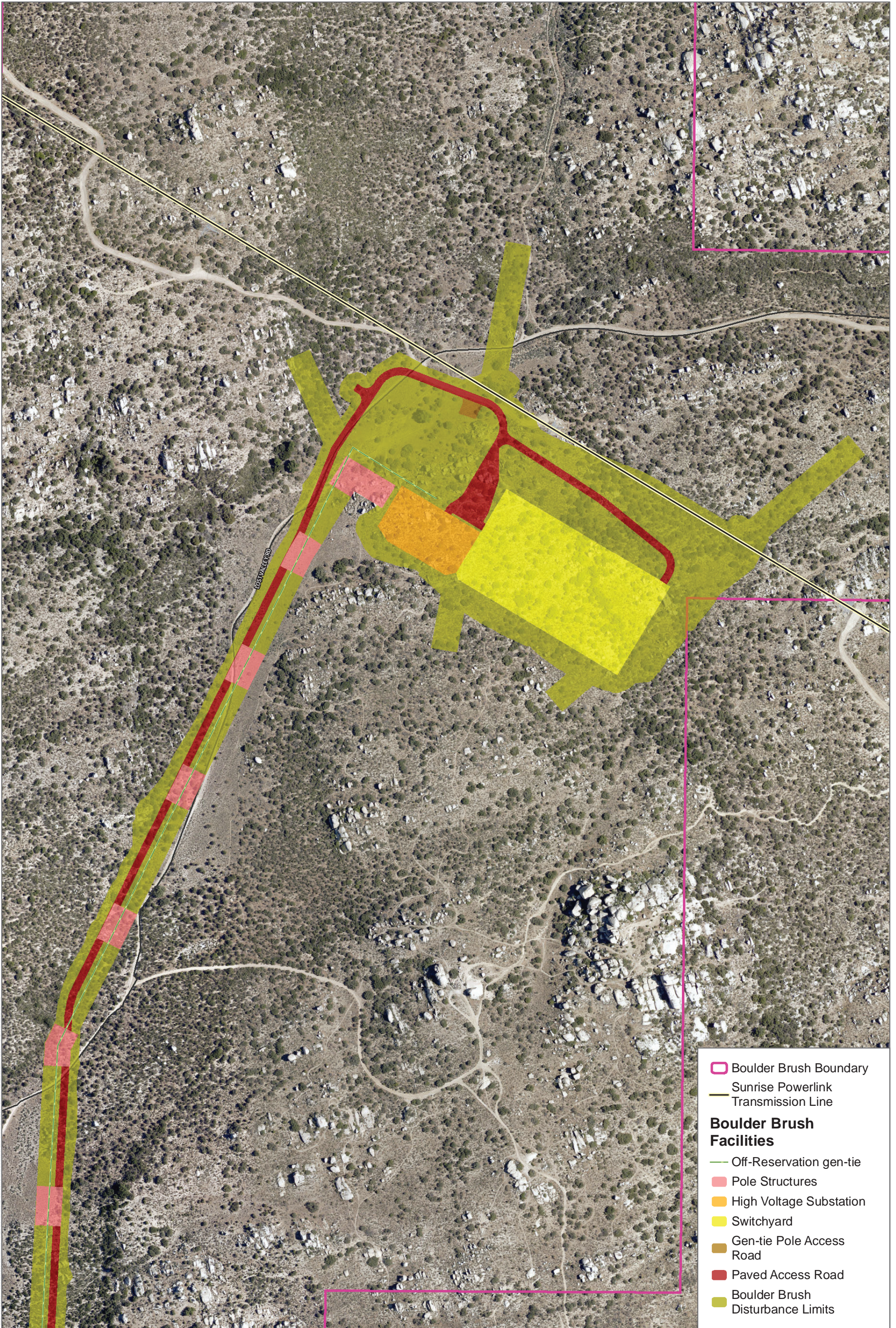

FIGURE 1-4A

Boulder Brush Site Plan

Campo Wind Project with Boulder Brush Facilities

INTENTIONALLY LEFT BLANK



SOURCE: SANGIS 2017



- Boulder Brush Boundary
- Sunrise Powerlink Transmission Line
- Boulder Brush Facilities**
- Off-Reservation gen-tie
- Pole Structures
- High Voltage Substation
- Switchyard
- Gen-tie Pole Access Road
- Paved Access Road
- Boulder Brush Disturbance Limits

Figure 1-4B

Boulder Brush Site Plan

Campo Wind Project with Boulder Brush Facilities

INTENTIONALLY LEFT BLANK

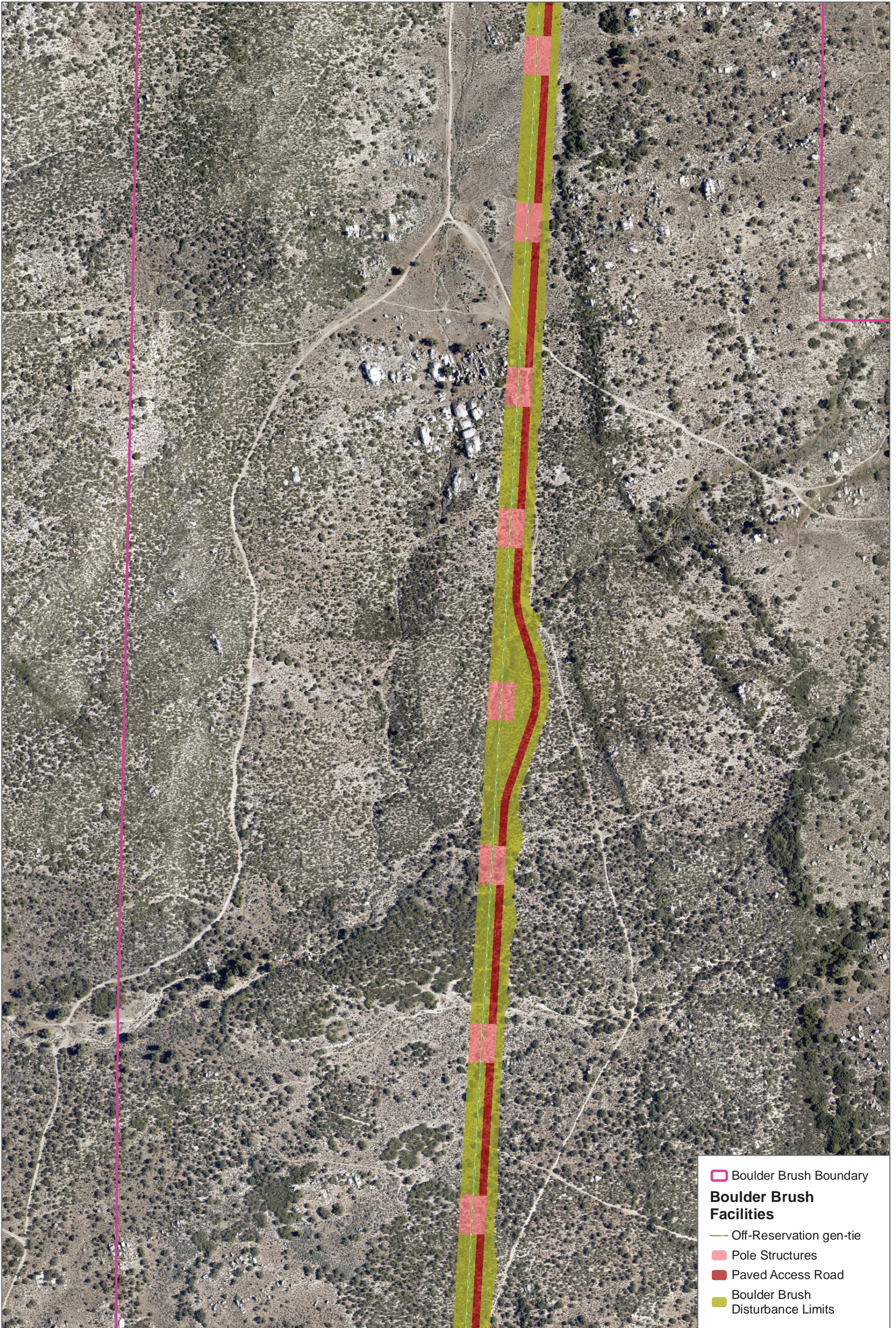

□ Boulder Brush Boundary
Boulder Brush Facilities
--- Off-Reservation gen-tie
■ Pole Structures
— Paved Access Road
 Boulder Brush Disturbance Limits

SOURCE: SANGIS 2017

INTENTIONALLY LEFT BLANK

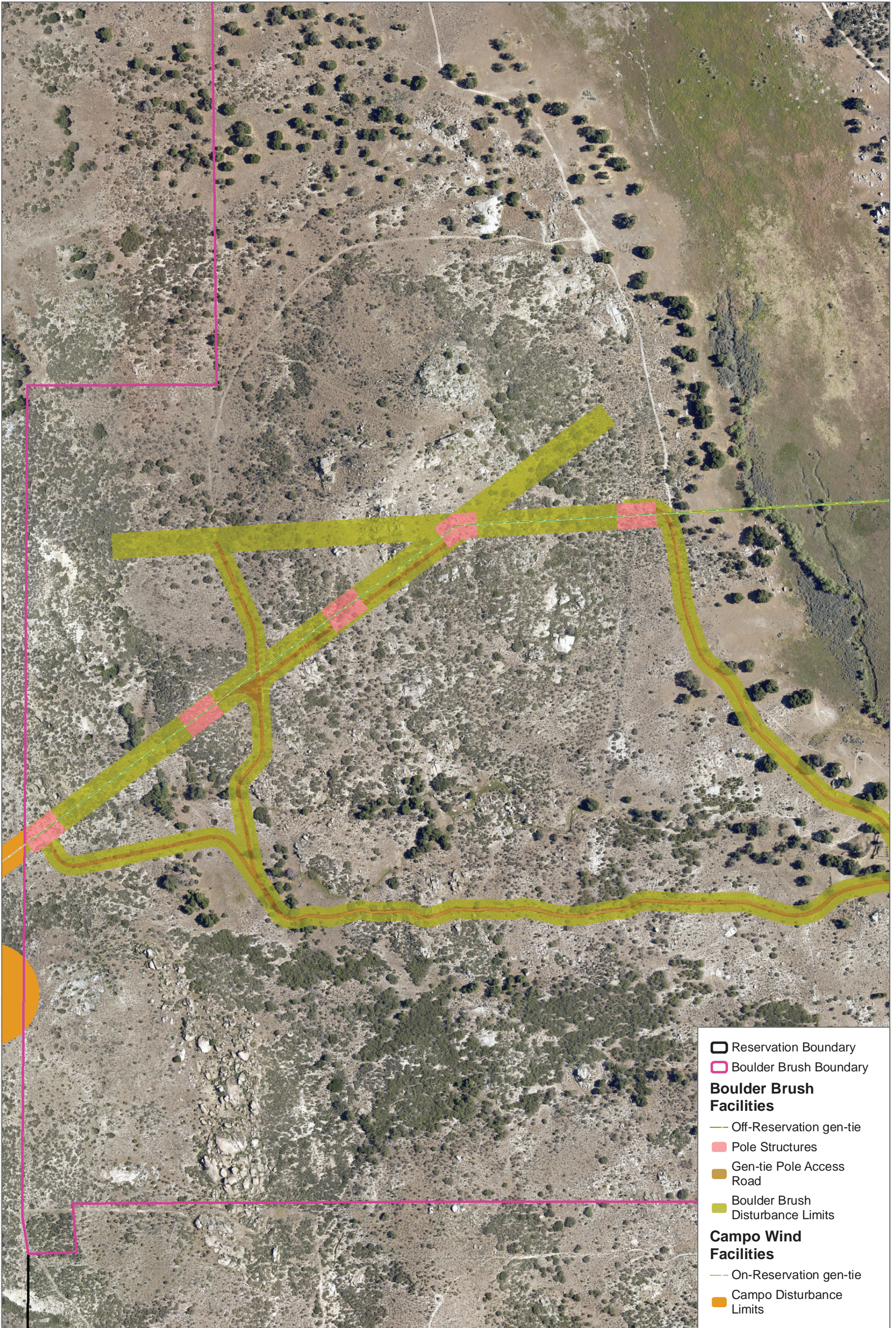

- Reservation Boundary
- Boulder Brush Boundary

Boulder Brush Facilities

- Off-Reservation gen-tie
- Pole Structures
- Gen-tie Pole Access Road
- Boulder Brush Disturbance Limits

Campo Wind Facilities

- On-Reservation gen-tie
- Campo Disturbance Limits

SOURCE: SANGIS 2017



Figure 1-4D
 Boulder Brush Site Plan
 Campo Wind Project with Boulder Brush Facilities

INTENTIONALLY LEFT BLANK

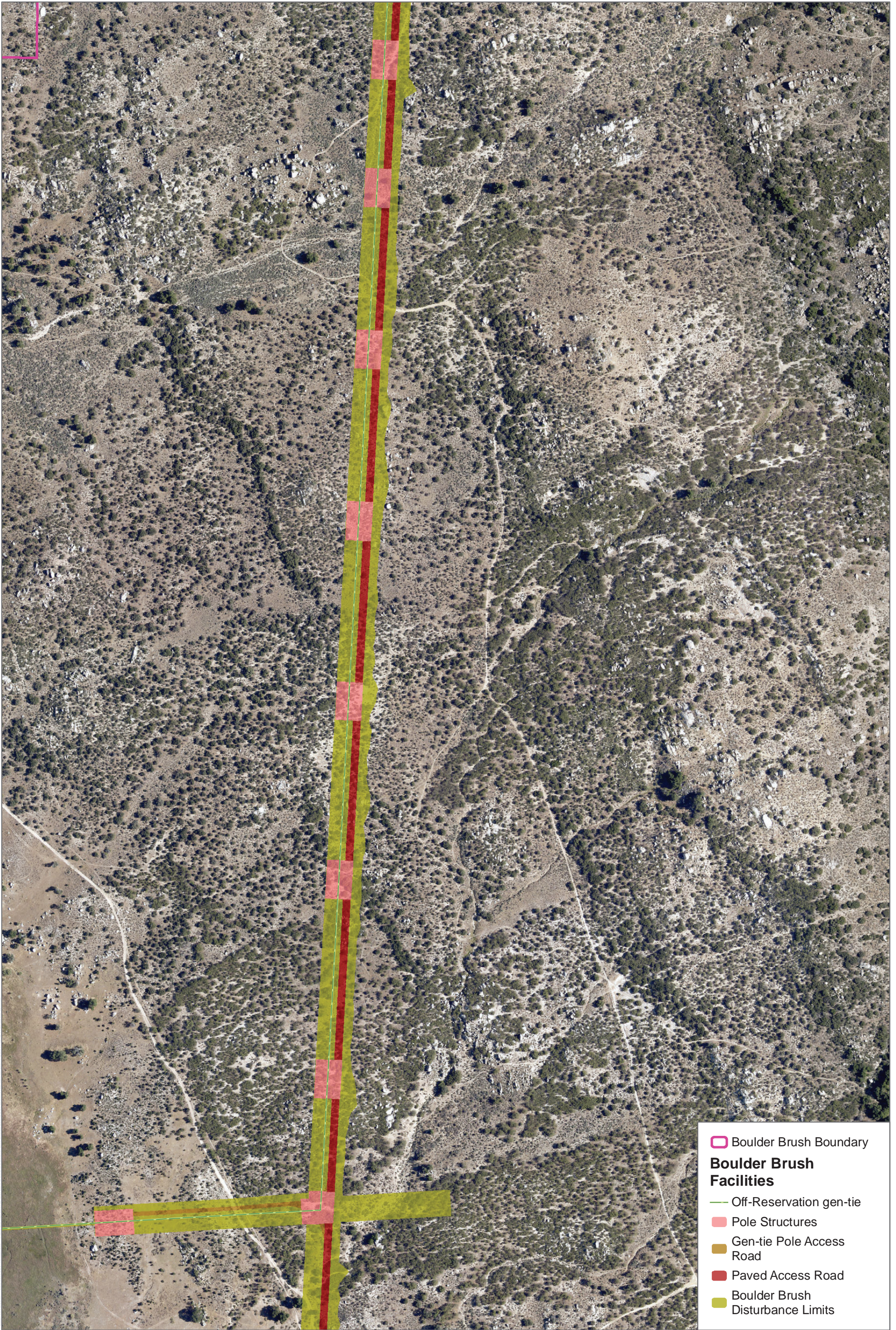

SOURCE: SANGIS 2017



- Boulder Brush Boundary
- Boulder Brush Facilities**
- Off-Reservation gen-tie
- Pole Structures
- Gen-tie Pole Access Road
- Paved Access Road
- Boulder Brush Disturbance Limits

Figure 1-4E

Boulder Brush Site Plan

Campo Wind Project with Boulder Brush Facilities

INTENTIONALLY LEFT BLANK

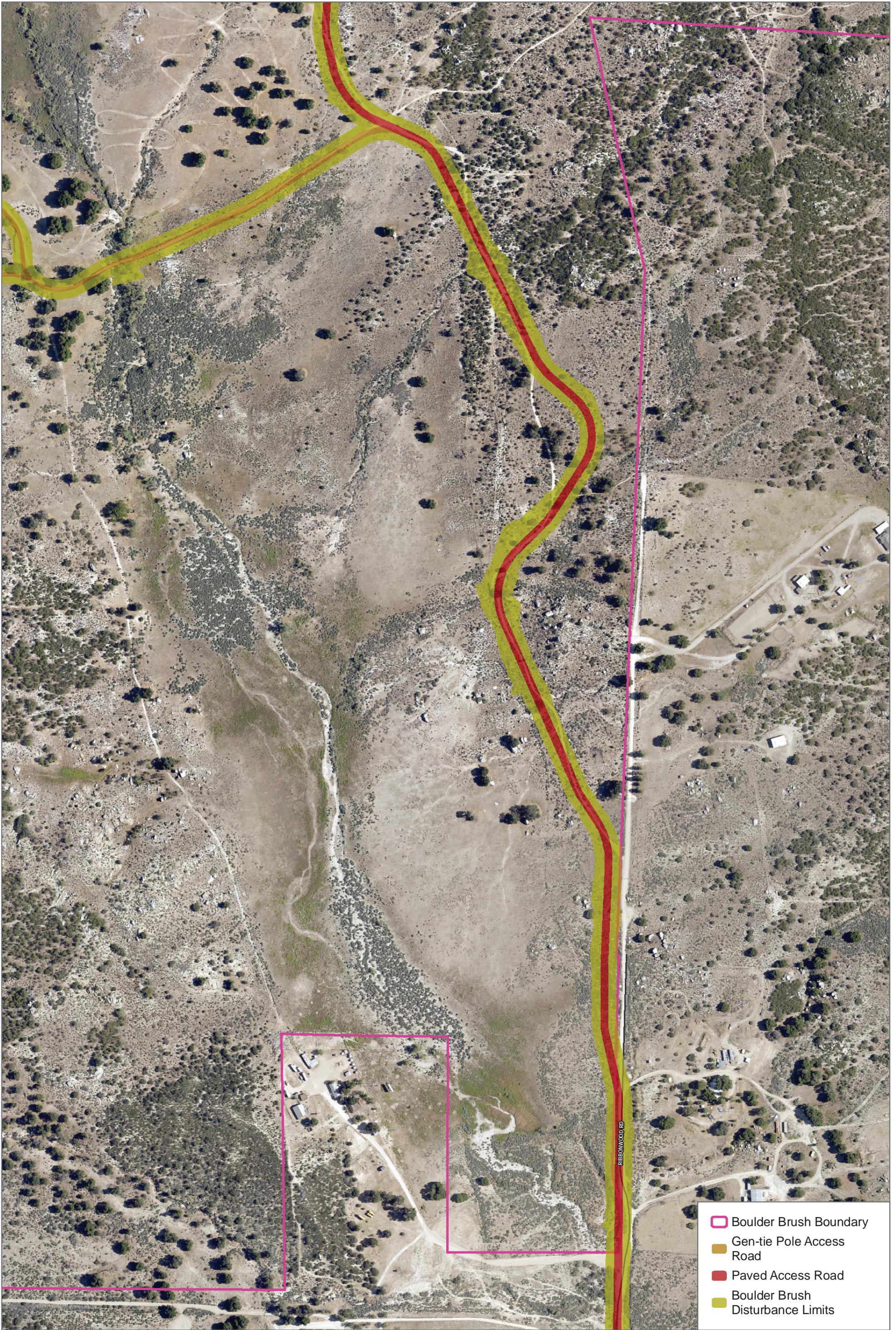

- Boulder Brush Boundary
- Gen-tie Pole Access Road
- Paved Access Road
- Boulder Brush Disturbance Limits

SOURCE: SANGIS 2017



Figure 1-4F
 Boulder Brush Site Plan
 Campo Wind Project with Boulder Brush Facilities

INTENTIONALLY LEFT BLANK

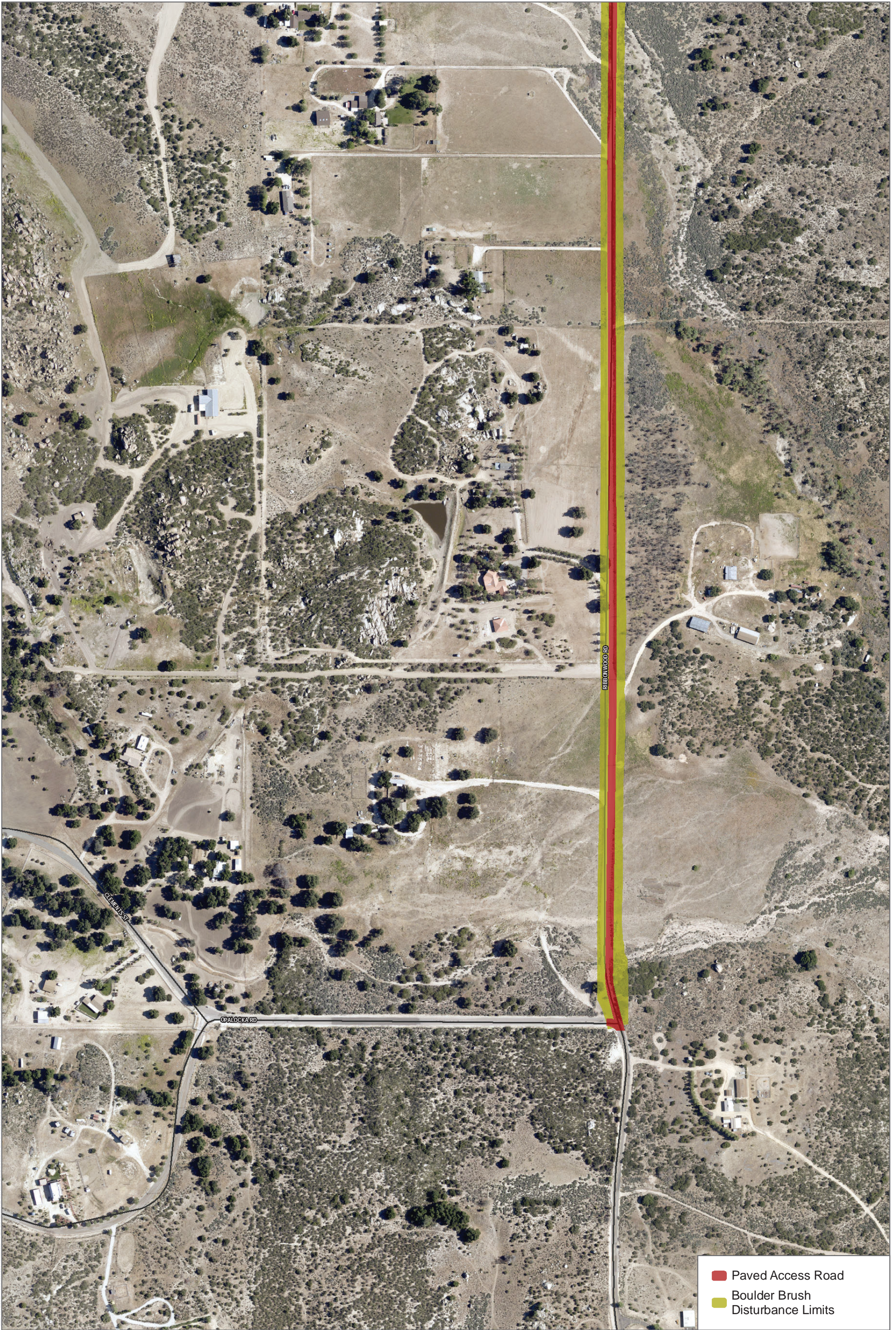

SOURCE: SANGIS 2017



- Paved Access Road
- Boulder Brush Disturbance Limits

Figure 1-4G
 Boulder Brush Site Plan
 Campo Wind Project with Boulder Brush Facilities

INTENTIONALLY LEFT BLANK

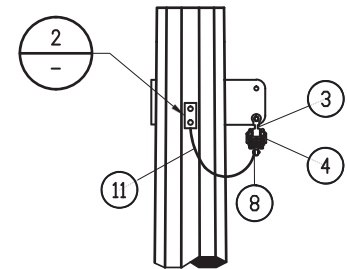
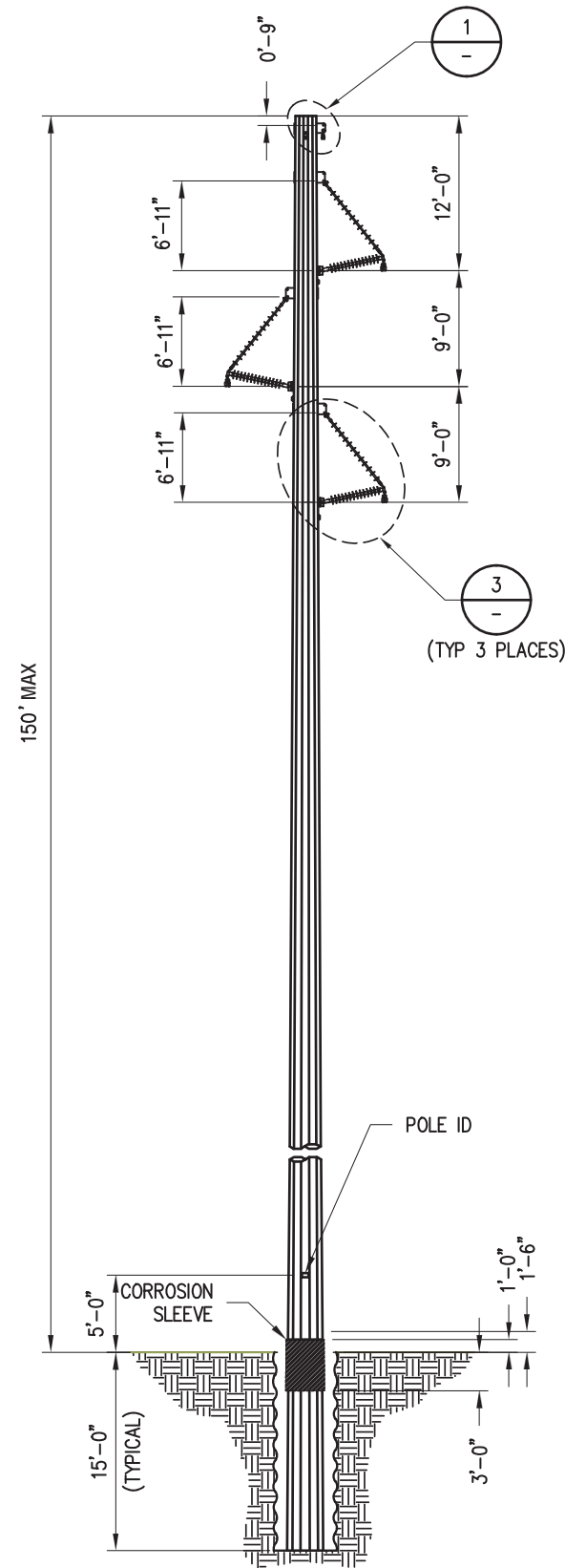

DETAIL NAME 1
OPGW ATTACHMENT TYP -

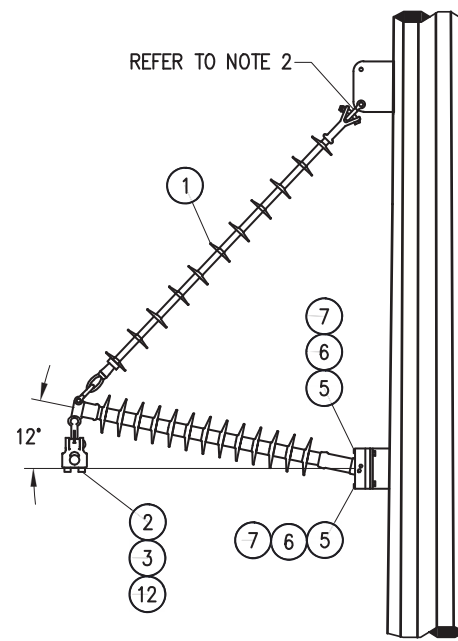

DETAIL 3
PHASE ATTACHMENT TYP -

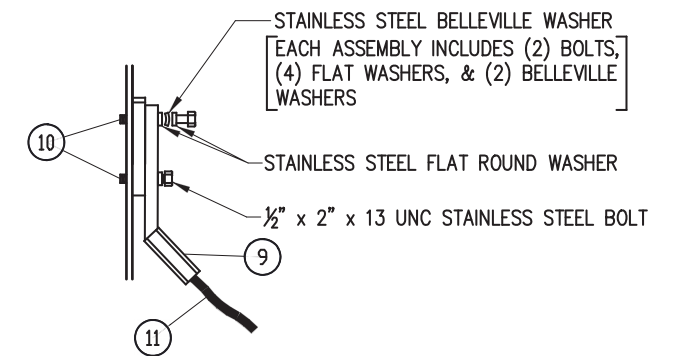

DETAIL 2
OPGW WIRE GROUNDING TYP -

Note: Actual Engineered Pole Structure Dimensions may differ

INTENTIONALLY LEFT BLANK

PRELIMINARY
NOT FOR CONSTRUCTION

0 8FT 16FT 32FT

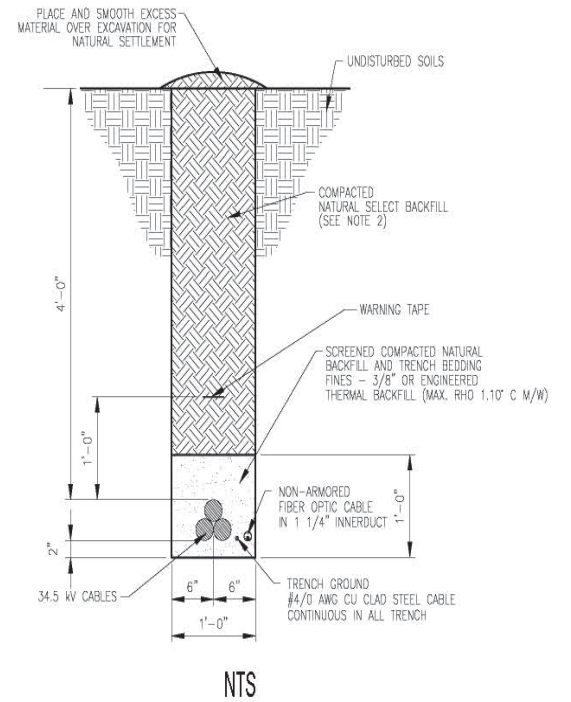
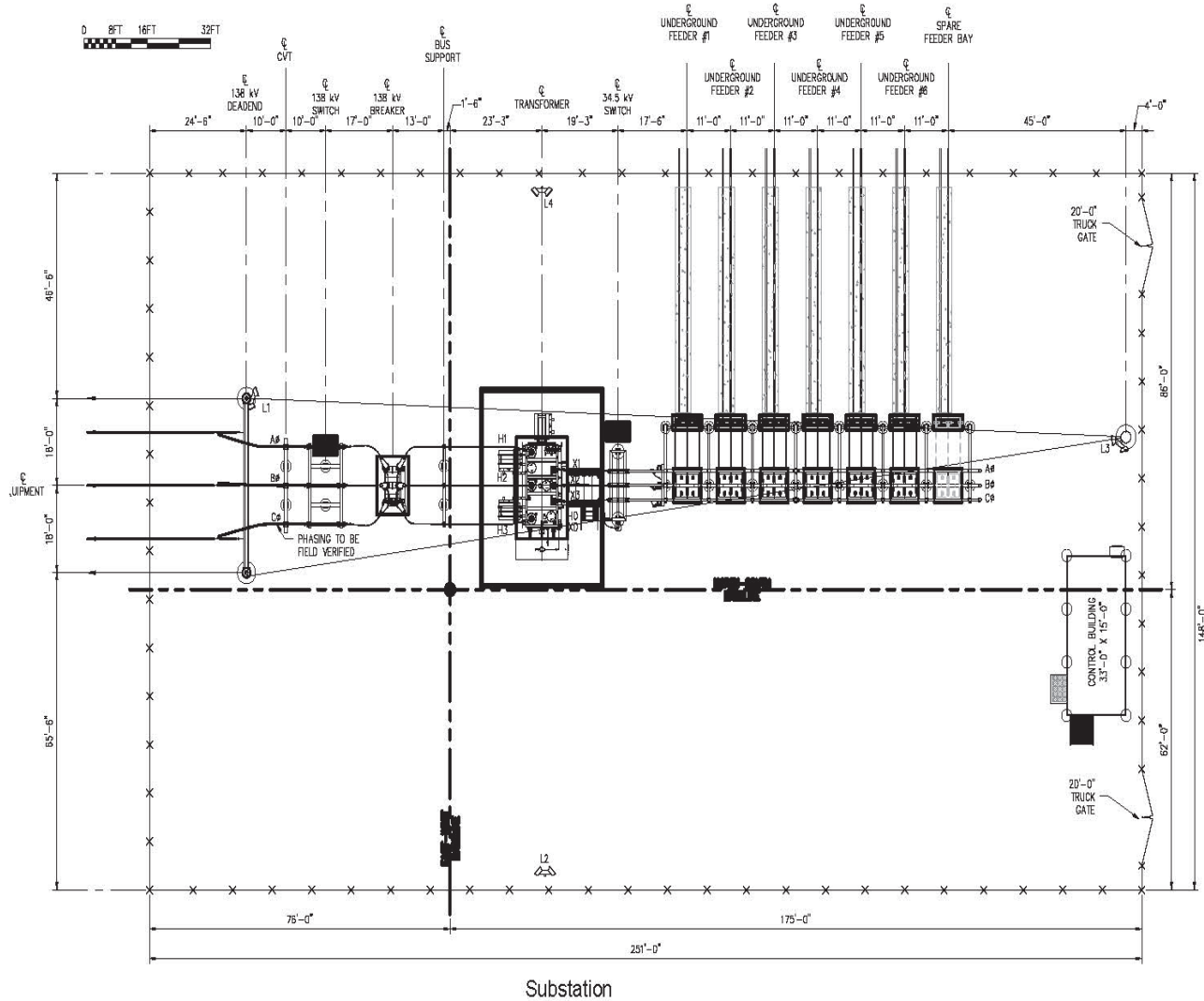

Typical Electrical Collection and Communications System

Note: Components and Dimensions for Project Collector Substation May Differ.

INTENTIONALLY LEFT BLANK

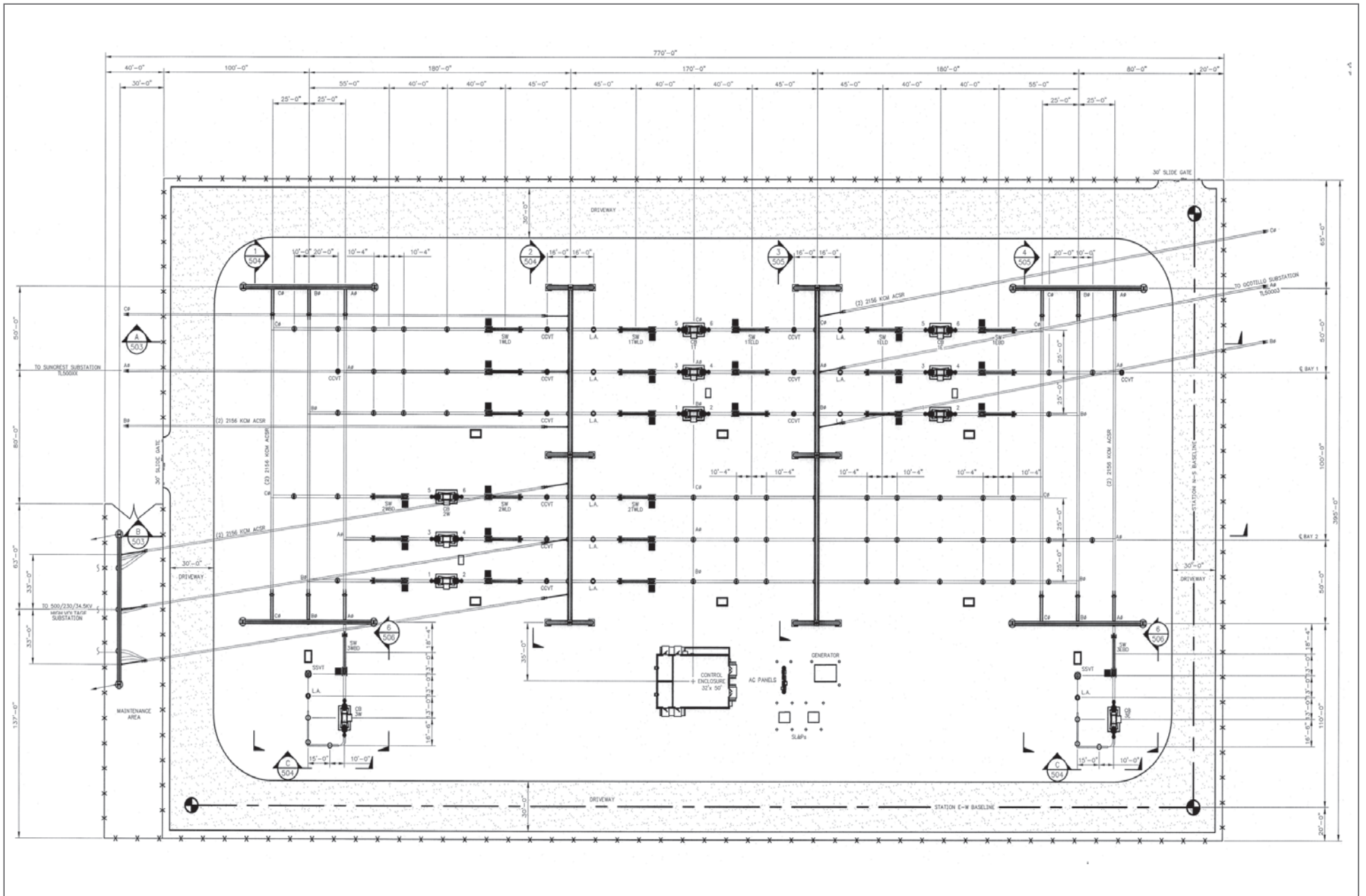

SOURCE: Beta Engineering 2019

FIGURE 1-7
Switchyard Layout

INTENTIONALLY LEFT BLANK

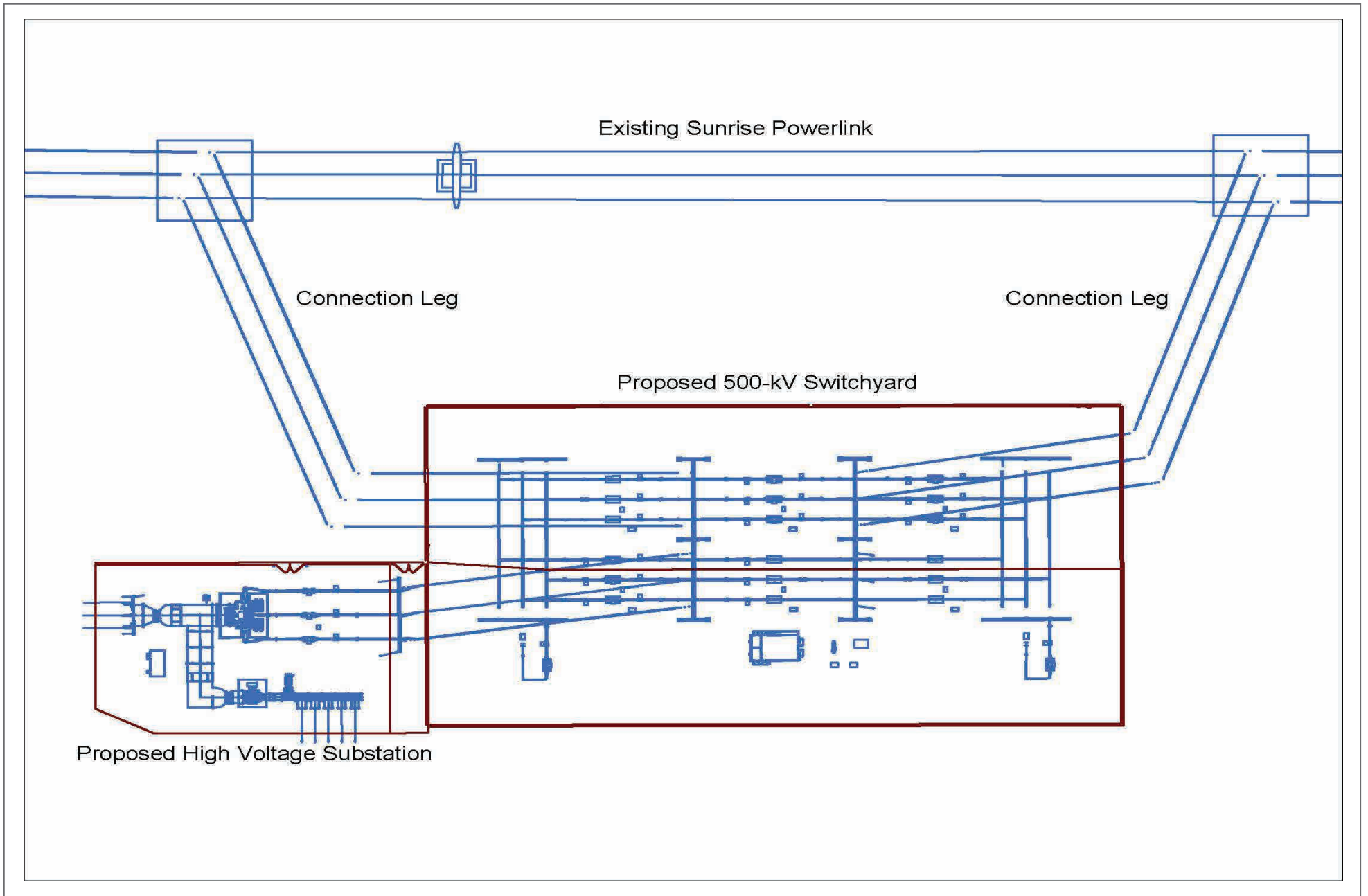
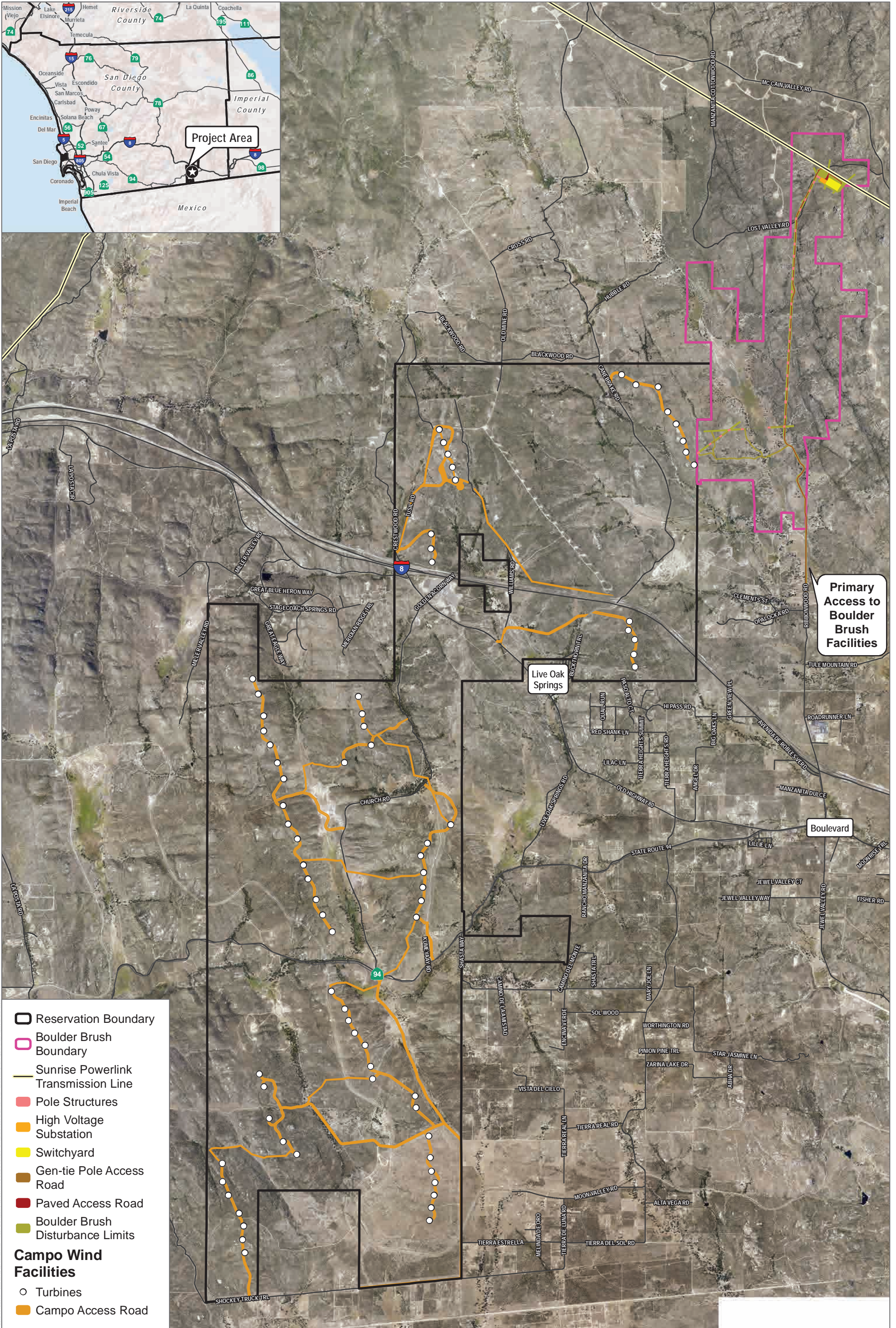

FIGURE 1-8

SDG&E Connection Schematic
Campo Wind Project with Boulder Brush Facilities

INTENTIONALLY LEFT BLANK



- Reservation Boundary
- Boulder Brush Boundary
- Sunrise Powerlink Transmission Line
- Pole Structures
- High Voltage Substation
- Switchyard
- Gen-tie Pole Access Road
- Paved Access Road
- Boulder Brush Disturbance Limits
- Campo Wind Facilities**
- Turbines
- Campo Access Road

SOURCE: SANGIS 2017



FIGURE 1-9A
Project Access Roads

Campo Wind Project with Boulder Brush Facilities

INTENTIONALLY LEFT BLANK

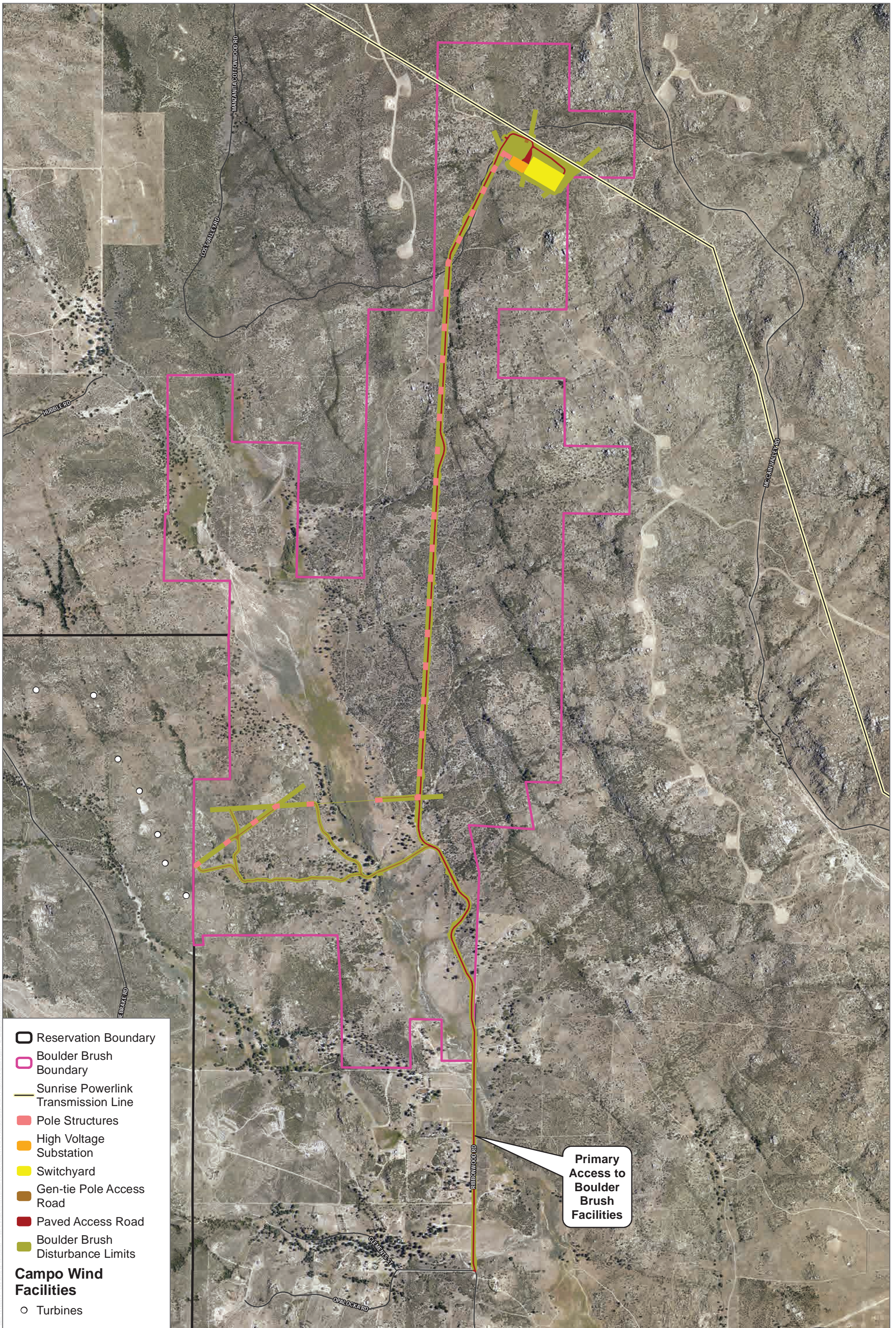

- Reservation Boundary
 - Boulder Brush Boundary
 - Sunrise Powerlink Transmission Line
 - Pole Structures
 - High Voltage Substation
 - Switchyard
 - Gen-tie Pole Access Road
 - Paved Access Road
 - Boulder Brush Disturbance Limits
- Campo Wind Facilities**
- Turbines

Primary Access to Boulder Brush Facilities

SOURCE: SANGIS 2017



FIGURE 1-9B

Boulder Brush Access Roads

Campo Wind Project with Boulder Brush Facilities

INTENTIONALLY LEFT BLANK

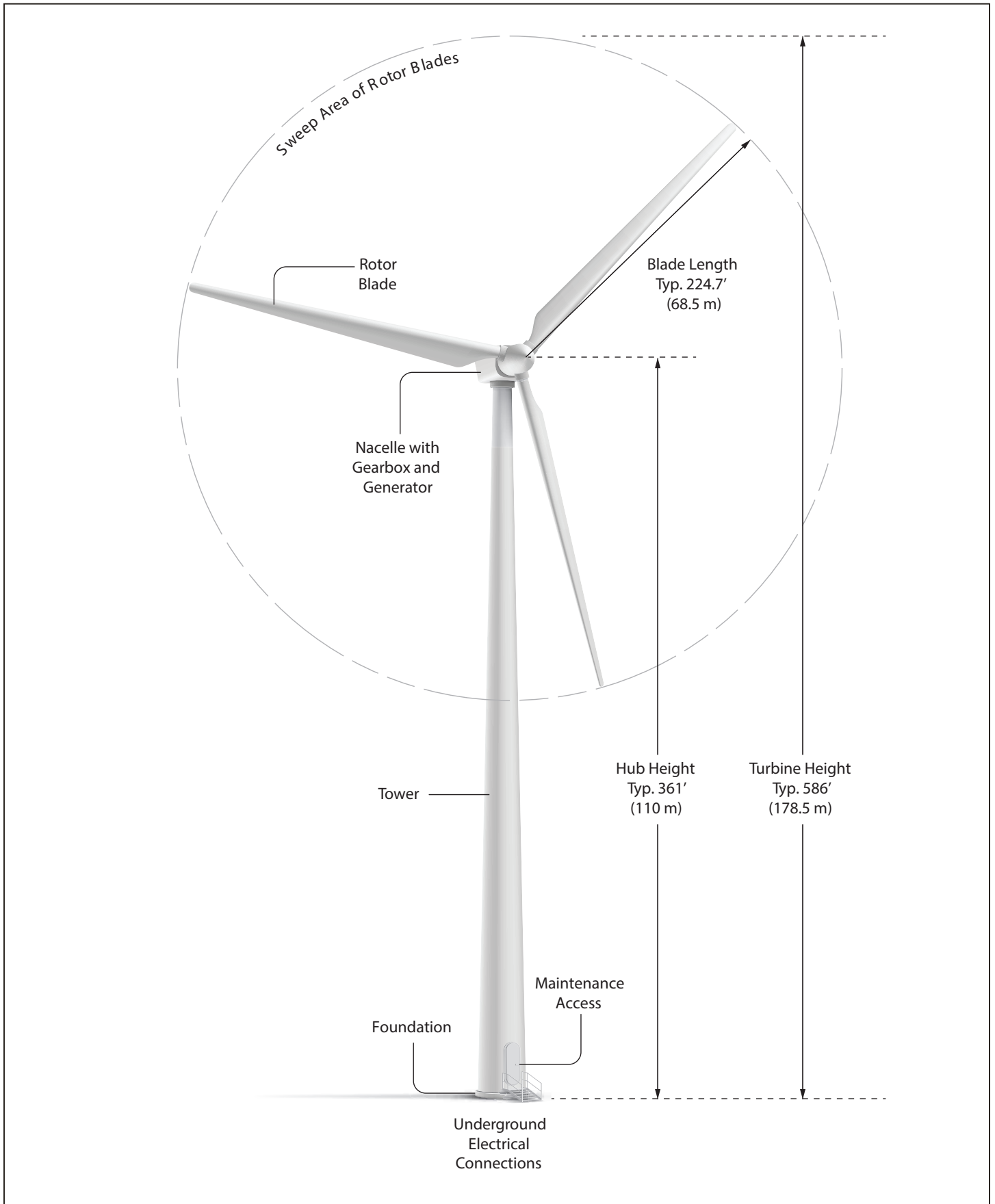
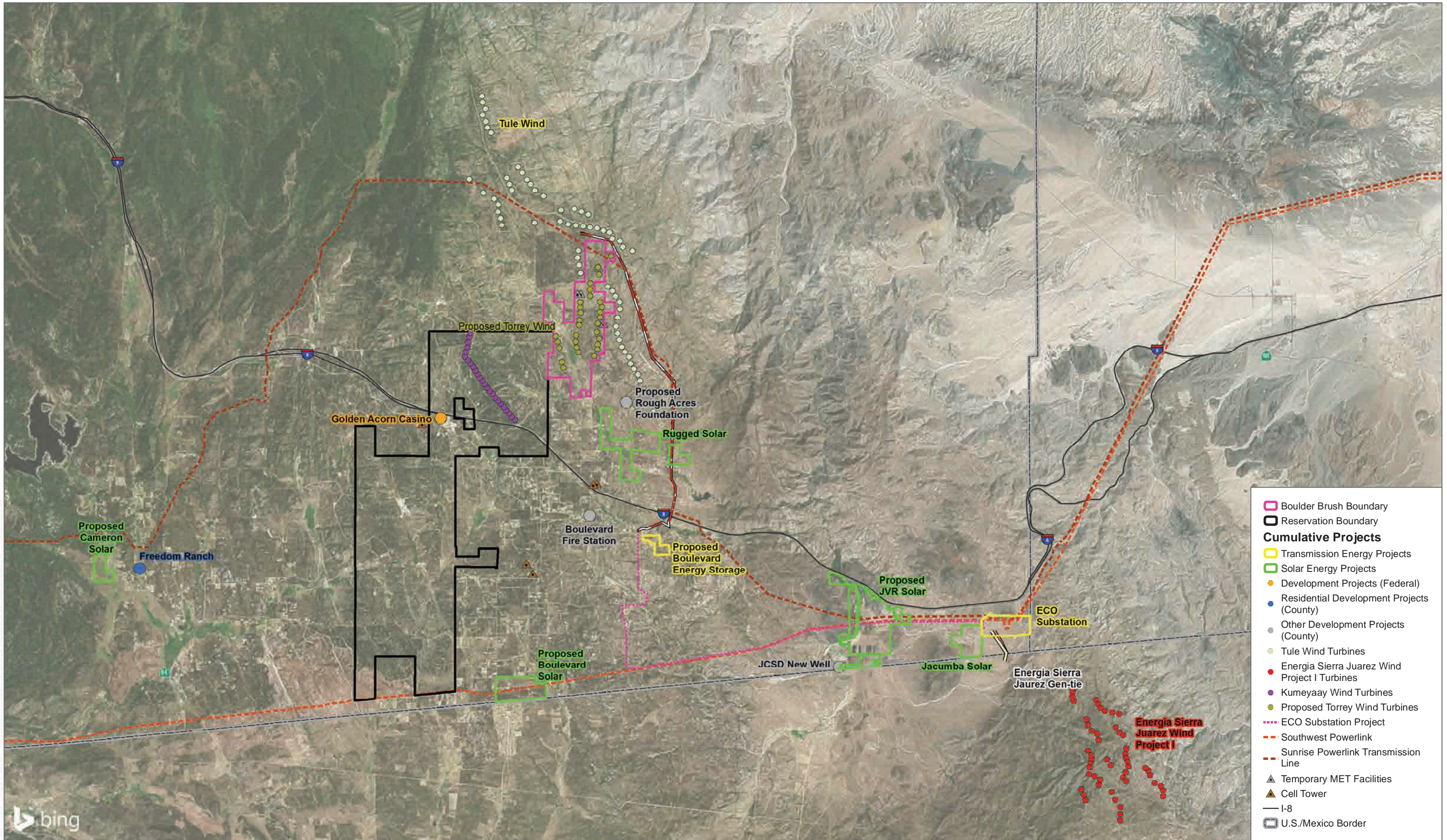

FIGURE 1-10

Typical Wind Turbine Specifications
Campo Wind Project with Boulder Brush Facilities

INTENTIONALLY LEFT BLANK

INTENTIONALLY LEFT BLANK



SOURCE: BING 2018; County of San Diego



FIGURE 1-12

Cumulative Projects

Campo Wind Project with Boulder Brush Facilities

INTENTIONALLY LEFT BLANK