

EASEMENTS

- (A) ITEM 7 EASEMENT FOR THE PURPOSE SHOWN BELOW AND RIGHTS INCIDENTAL THERETO AS GRANTED IN DOCUMENT:**  
 GRANTED TO: SAN DIEGO GAS AND ELECTRIC COMPANY  
 PURPOSE: UNDERGROUND FACILITIES AND ABOVE GROUND STRUCTURES  
 RECORDING DATE: FEBRUARY 13, 1958  
 RECORDING NO: BOOK 6948, PAGE 398, OF OFFICIAL RECORDS SAID LAND MORE PARTICULARLY DESCRIBED THEREIN
- (B) ITEM 9 EASEMENT FOR THE PURPOSE SHOWN BELOW AND RIGHTS INCIDENTAL THERETO AS GRANTED IN DOCUMENT:**  
 GRANTED TO: SPRING VALLEY SANITATION DISTRICT  
 PURPOSE: SEWER LINE  
 RECORDING DATE: MARCH 9, 1962  
 RECORDING NO: 40574, OF OFFICIAL RECORDS
- (C) ITEM 10 EASEMENT FOR THE PURPOSE SHOWN BELOW AND RIGHTS INCIDENTAL THERETO AS GRANTED IN DOCUMENT:**  
 GRANTED TO: COUNTY OF SAN DIEGO  
 PURPOSE: SLOPES  
 RECORDING DATE: NOVEMBER 18, 1964  
 RECORDING NO: 210201, OF OFFICIAL RECORDS
- (D) ITEM 11 EASEMENT FOR THE PURPOSE SHOWN BELOW AND RIGHTS INCIDENTAL THERETO AS SET FORTH IN DOCUMENT:**  
 PURPOSE: RIGHTS OF WAY TO INSTALL AND MAINTAIN WATER LINES  
 RECORDING DATE: OCTOBER 16, 1967  
 RECORDING NO: 160118, OF OFFICIAL RECORDS
- (E) ITEM 14 EASEMENT FOR THE PURPOSE SHOWN BELOW AND RIGHTS INCIDENTAL THERETO AS SET FORTH IN DOCUMENT:**  
 PURPOSE: Off-site drainage  
 RECORDING DATE: JULY 18, 2017  
 RECORDING NO: 2017-0322840, OF OFFICIAL RECORDS

**PRELIMINARY GRADING PLAN NOTE:**  
 THIS PLAN IS PROVIDED TO ALLOW FOR THE FULL AND ADEQUATE DISCRETIONARY REVIEW OF A PROPOSED DEVELOPMENT PROJECT. THE PROPERTY OWNER ACKNOWLEDGES THAT ACCEPTANCE OR APPROVAL OF THIS PLAN DOES NOT CONSTITUTE AN APPROVAL TO PERFORM ANY GRADING SHOWN HEREIN, AND AGREES TO OBTAIN A VALID GRADING PERMIT BEFORE COMMENCING SUCH ACTIVITY.

PRELIMINARY GRADING PLAN

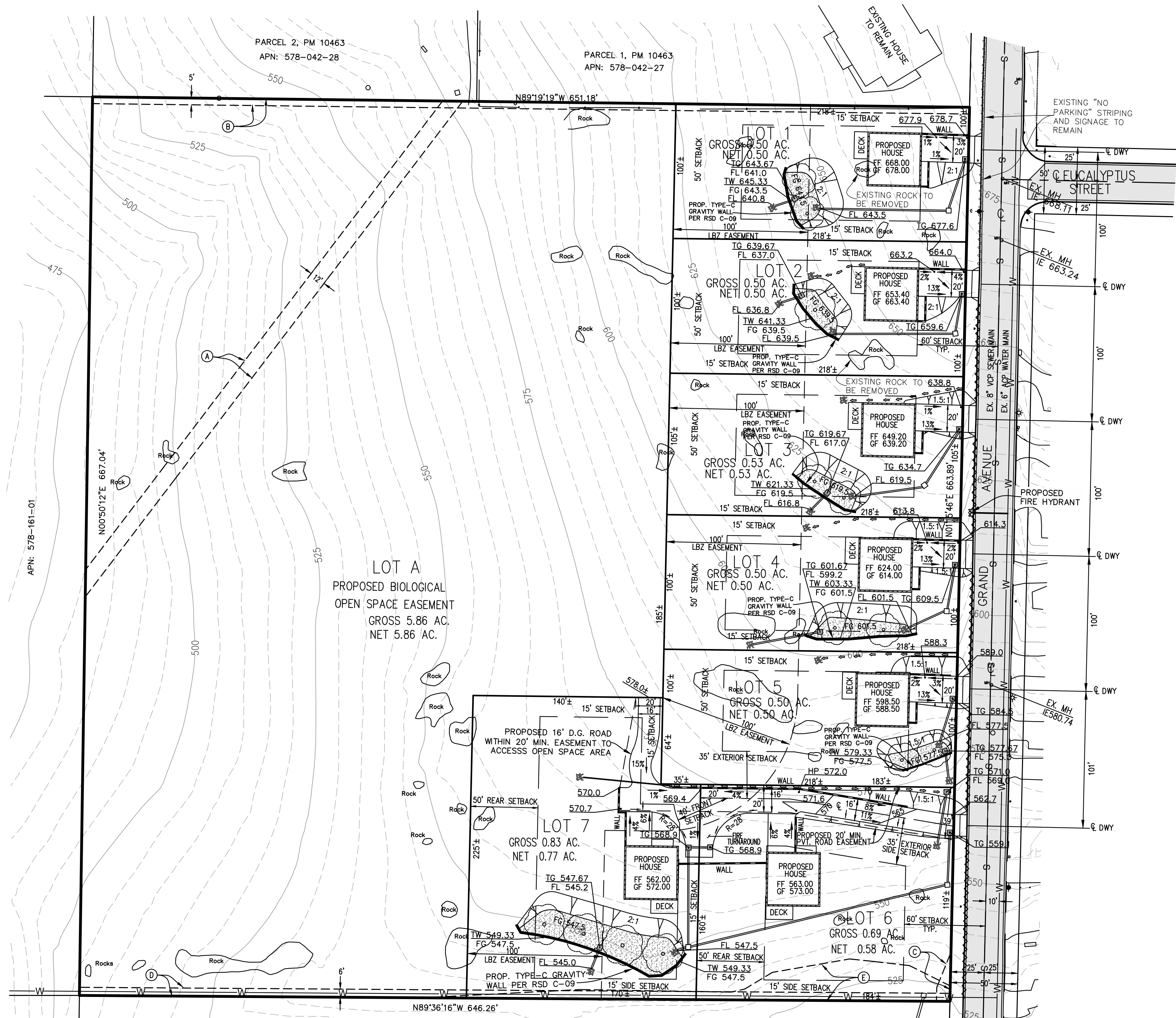

LEGEND

- BOUNDARY
- LOT LINES
- EASEMENTS
- FF FINISH FLOOR ELEVATION
- GF GARAGE FLOOR ELEVATION
- PROPOSED CUT SLOPES
- PROPOSED FILL SLOPES (2:1 TYP)
- PROPOSED CATCH BASIN
- PROPOSED CLEANOUT
- PROPOSED PCC BROW DITCH
- PROPOSED RIP RAP
- PROPOSED RETAINING WALL
- EASEMENT DESCRIPTION
- OPEN SPACE FENCING AND SIGNAGE
- TREE IN TREE WELL (SEE TABLE BELOW FOR TREE CANOPY SIZES)
- EXISTING "NO PARKING" STRIPING AND SIGNAGE
- PROPOSED "NO PARKING" RED CURB STRIPING AND SIGNAGE
- PROPOSED DRIVEWAY APRON PER RSD G-14A
- EXISTING ROCK TO REMAIN (TYPICAL) UNLESS OTHERWISE SPECIFIED

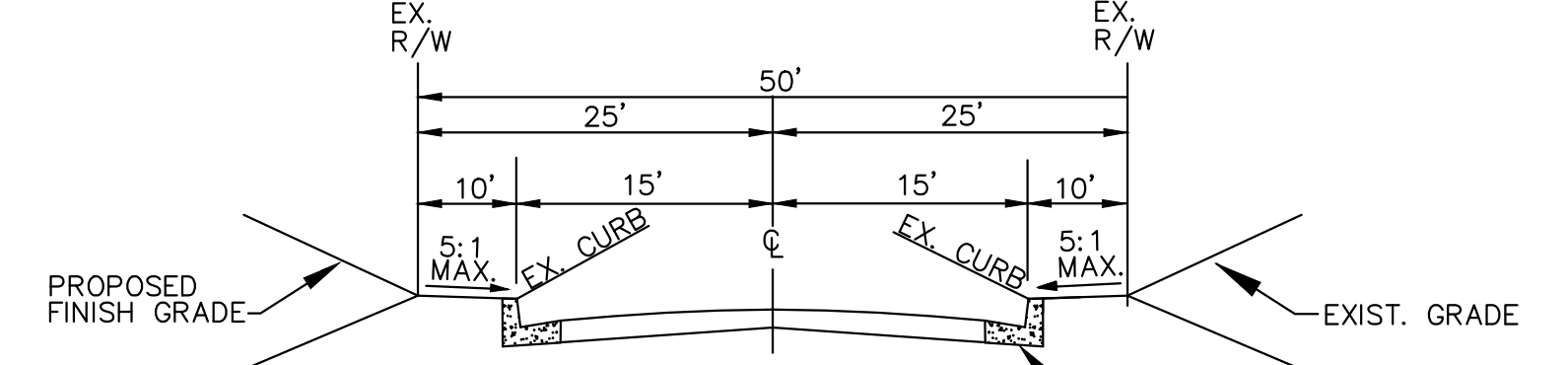

HILLSIDE RESIDENTIAL STREET ALTERNATE NO.1 PER RSD DS-2  
 GRAND AVENUE  
 NO SCALE

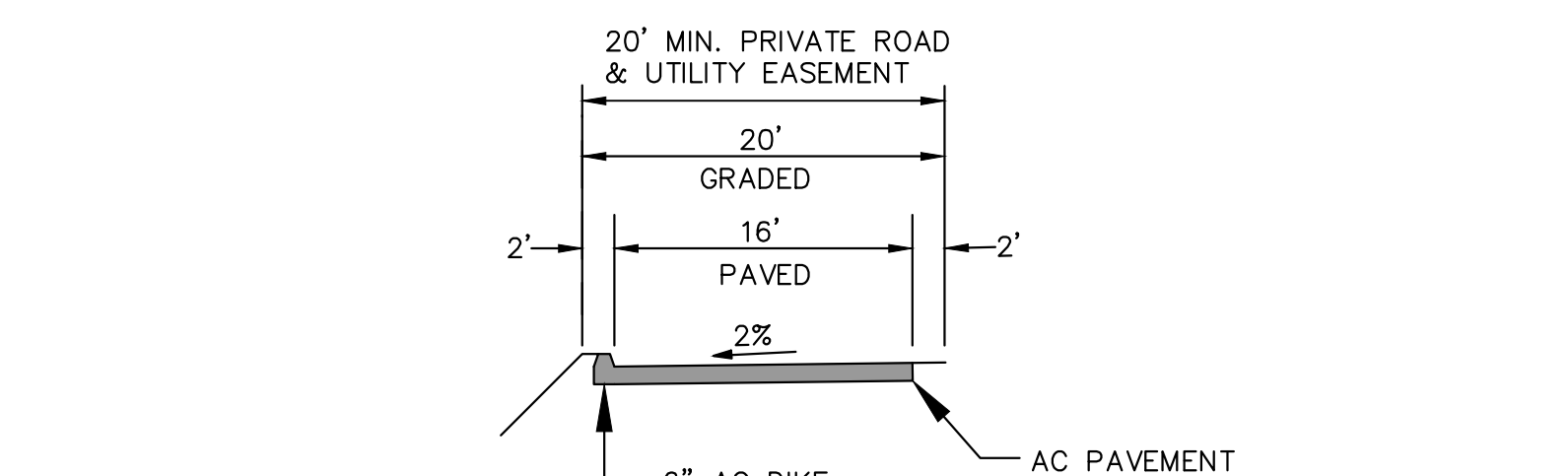

PRIVATE DRIVEWAY  
 NO SCALE

LOT #	MAX. ELEVATION DIFFERENCE BETWEEN 1ST FLOOR PERIMETER AND ADJACENT FINISHED GRADE (12" MAX. ALLOWABLE)	PERCENTAGE OF 1ST FLOOR PERIMETER THAT IS MORE THAN 6" ABOVE ADJACENT FINISHED GRADE (50% MAX. ALLOWABLE)
1	12.0'	50%
2	7.0'	5%
3	10.0'	35%
4	4.5'	0%
5	3.0'	0%
6	11.0'	40%
7	6.3'	5%

**SITE ADDRESS:**  
 GRAND AVENUE  
 SPRING VALLEY, CA 91977  
**APN:**  
 578-161-02

EARTHWORK:

LOT #	CUT (CY)	FILL (CY)
1	190	190
2	160	160
3	250	250
4	480	60
5	590	30
6 & 7	980	980
TOTAL	2,650	1,670

NOTE: LOTS 4 & 5 REQUIRE 420 CY & 560 CY OF EXPORT, RESPECTIVELY, UNLESS THE EXCESS DIRT IS TO BE PLACED ON EACH LOT AS FILL TO OFFSET THE EXPORT.

**PREPARED BY:**  
 LAWRENCE W. WALSH  
 Walsh Engineering & Surveying, Inc.  
 607 Aldwych Road, El Cajon, CA 92020  
 (619) 588-6747 (619) 792-1232 Fax



TREE WELL SUMMARY

LOT #	DMA	NO. OF TREE WELLS	MATURE CANOPY DIAMETER	SOIL DIMENSIONS PER TREE
1	1	2	25'	18' x 19.3' x 3'
2	2	1	30'	13.5' x 38' x 3'
3	3	2	25'	12.4' x 23' x 3.5'
4	4	2	25'	12' x 34' x 2.5'
5	5	2	25'	12' x 21.3' x 4'
7	6	4	30'	21' x 29.5' x 2.5'

**NOTE:**  
 AMENDED SOIL THICKNESS VARIES DEPENDING ON TREE WELL:  
 - TREE WELLS IN LOTS 4 & 7 HAVE 2.5' OF AMENDED SOIL  
 - TREE WELLS IN LOTS 1 & 2 HAVE 3.0' OF AMENDED SOIL  
 - TREE WELL IN LOT 3 HAS 3.5' OF AMENDED SOIL  
 - TREE WELL IN LOT 5 HAS 4.0' OF AMENDED SOIL

ONE 1.5" ORIFICE TO SEPARATE WATER QUALITY LAYER FROM FLOOD DETENTION STORAGE LAYER PER HYDRAULIC DESIGN MANUAL REQUIREMENTS (NOTE: EXCEPTIONS ARE THAT TREE WELL IN LOT 3 HAS ONE 1.75" ORIFICE & LOT 7 HAS ONE 4" ORIFICE)

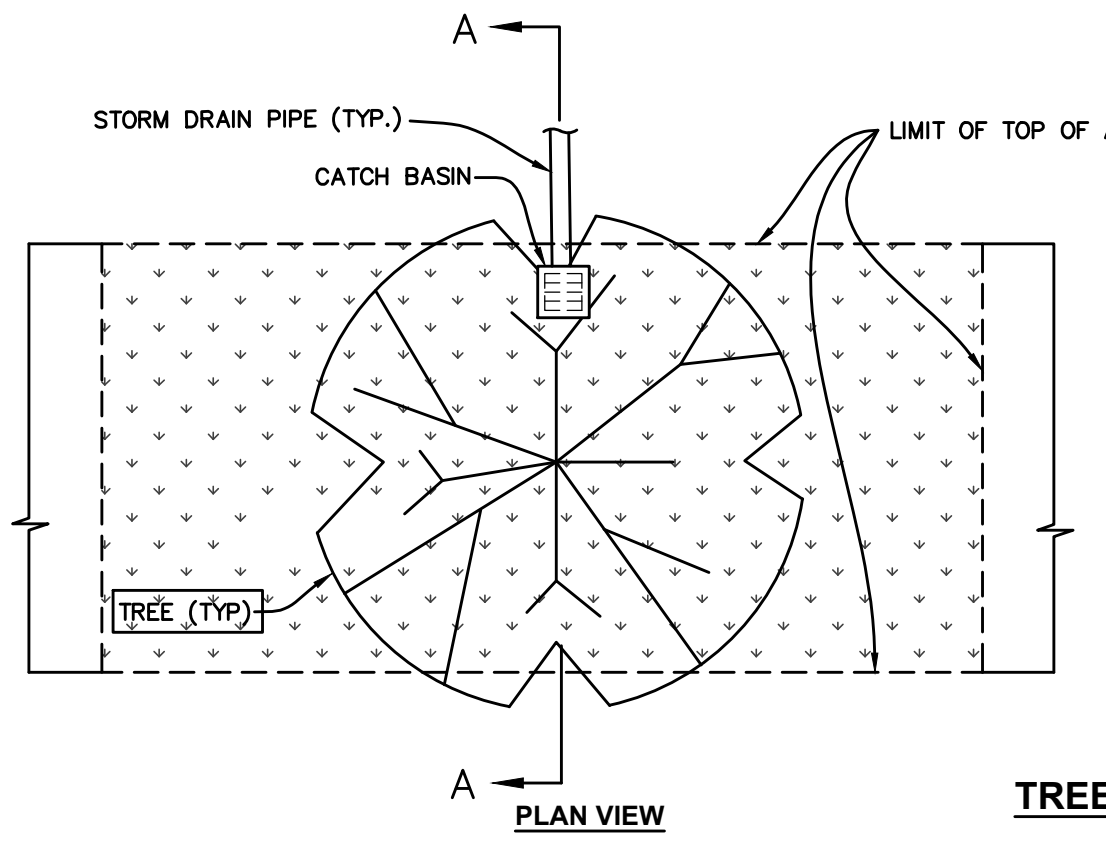

TREEWELL DETAIL  
 NO SCALE

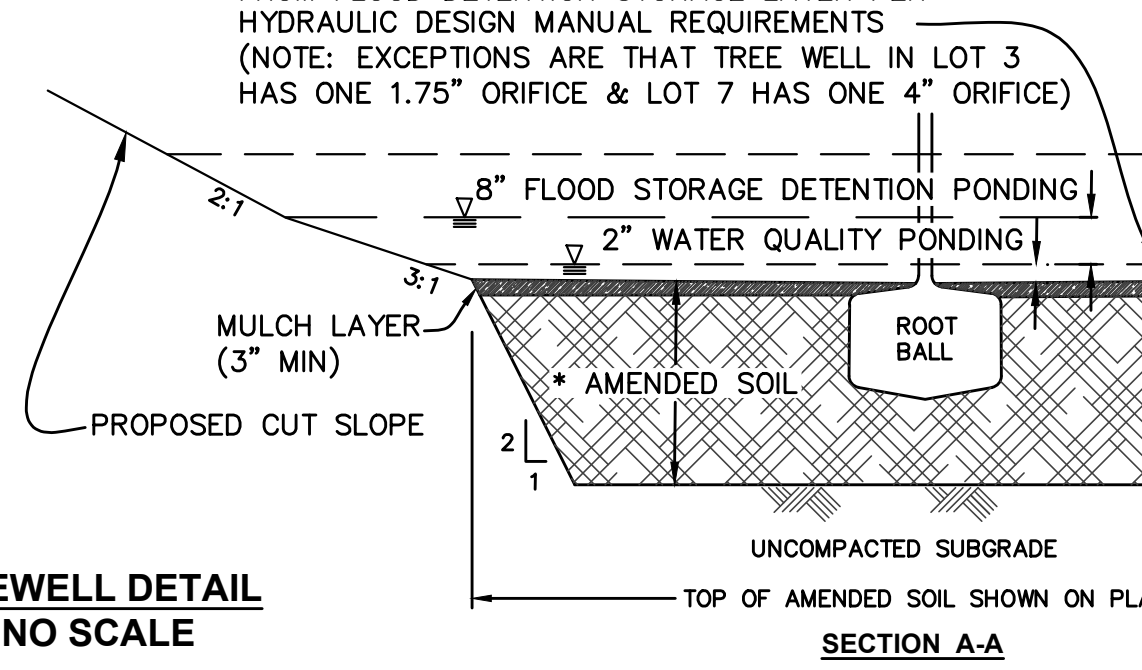

SECTION A-A

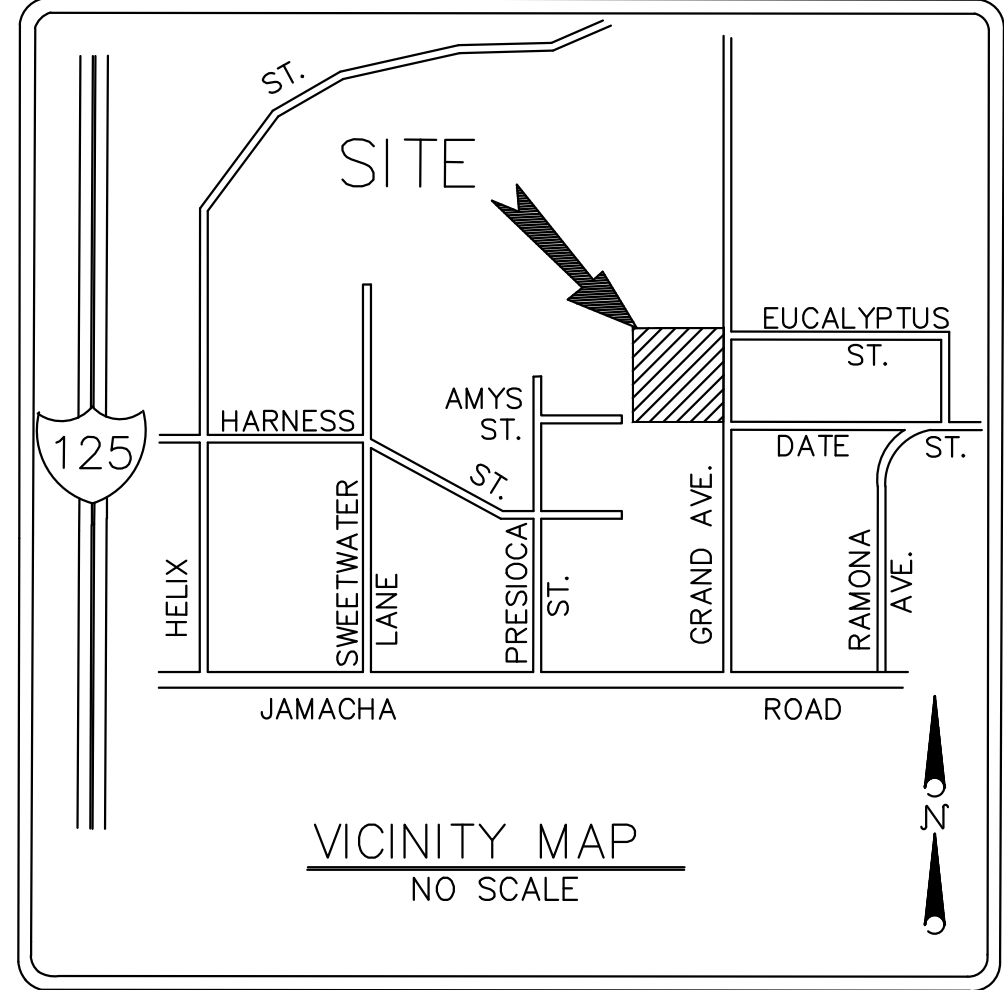

VICINITY MAP  
 NO SCALE

