

**EASEMENT NOTE**  
 EASEMENTS OF RECORD NOT SHOWN HEREON SHALL BE HONORED, ABANDONED AND / OR RELOCATED TO THE SATISFACTION OF ALL INTERESTED PARTIES. PUBLIC UTILITY EASEMENTS NECESSARY TO SERVE THIS PROJECT WILL BE COORDINATED WITH THE SERVING UTILITY COMPANY.

**SOURCE OF TOPOGRAPHY**  
 TOPOGRAPHY SHOWN ON THESE PLANS WAS GENERATED BY PHOTOGRAMMETRIC METHODS FROM INFORMATION GATHERED ON 10-11-2013 BY AEROTECH MAPPING. TOPOGRAPHY SHOWN HEREON CONFORMS TO NATIONAL MAP ACCURACY STANDARDS.

**ACCESS**  
 THE ACCESS TO THIS PROJECT IS VIA THE PROPOSED PRIVATE ROADS "A", "B", "C", & "E". ROADS "E" CONNECTS TO THE EXISTING PUBLIC SAN ELMO ROAD.

**ASSESSOR'S PARCEL NUMBERS**  
 223-080-46-00, 223-070-07-00 & 223-070-08-00

**LEGAL DESCRIPTION**  
 THE WEST HALF OF THE NORTHWEST QUARTER OF SECTION 33, TOWNSHIP 12 SOUTH, RANGE 3 WEST, SAN BERNARDINO MERIDIAN, IN THE COUNTY OF SAN DIEGO, STATE OF CALIFORNIA, ACCORDING TO THE OFFICIAL PLAT THEREOF, EXCEPTING THEREFROM THE WESTERLY 100 FEET OF THE NORTHERLY 100 FEET THEREOF.

ALSO EXCEPTING THEREFROM ALL THAT PORTION OF THE WEST HALF OF THE NORTHWEST QUARTER OF SECTION 33, TOWNSHIP 12, RANGE 3 WEST, SAN BERNARDINO MERIDIAN, IN THE COUNTY OF SAN DIEGO, STATE OF CALIFORNIA,

ALSO EXCEPTING THEREFROM THAT PORTION DESCRIBED IN GRANT DEED TO THE CITY OF SAN MARCOS RECORDED JUNE 6, 2003, AS INSTRUMENT NO. 2003399 OF OFFICIAL RECORDS

**INDEX SHEET**  
 SHEET 1 - TITLE  
 SHEET 2 - LOT SUMMARY  
 SHEET 3 - SITEPLAN  
 SHEET 4 - SITEPLAN

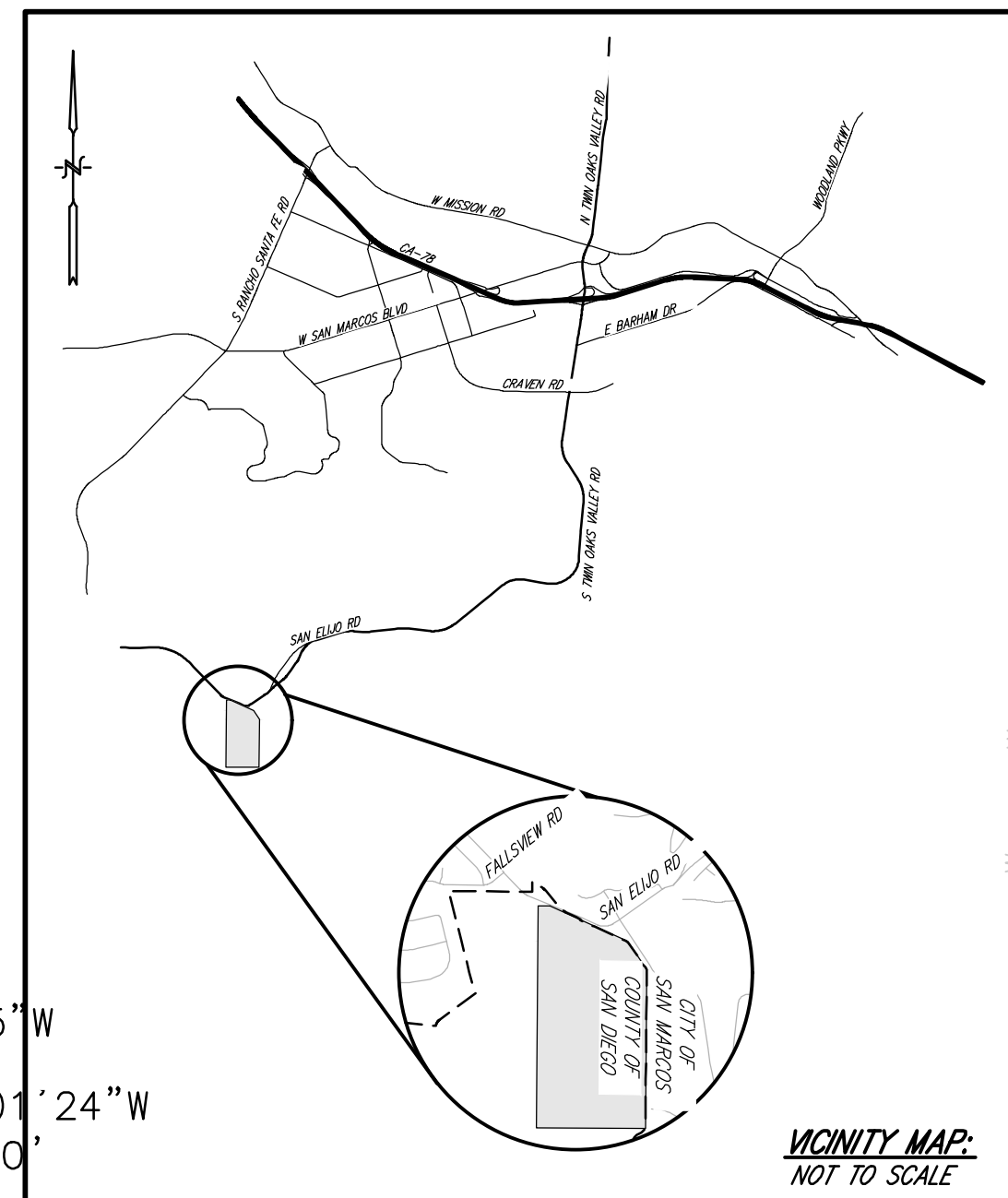

**OWNER'S CERTIFICATE**

I HEREBY CERTIFY THAT I AM THE RECORD OWNER OF THE PROPERTY SHOWN ON THIS TENTATIVE SUBDIVISION MAP AND THAT SAID MAP SHOWS MY ENTIRE CONTIGUOUS OWNERSHIP. I UNDERSTAND THAT THE PROPERTY IS CONSIDERED CONTIGUOUS EVEN IF IT IS SEPARATED BY ROADS, STREETS, UTILITY EASEMENTS OR RAILROAD RIGHTS OF WAY.

OWNER: OR QUESTHAVEN, LLC  
 DATE: February 21, 2024

OWNER / DEVELOPER: OR QUESTHAVEN, LLC

DANNY GABRIEL, PRESIDENT  
 DATE: February 21, 2024

**DEVELOPER ADDRESS**

444 WEST BEECH STREET  
 SUITE 300  
 SAN DIEGO, CA 92101

**EARTHWORK QUANTITIES:**

THE PRESDIAL VOLUME METHOD WAS USED TO CALCULATE THE VALUES SHOWN HEREON. SECTIONS OF STREETS, BIO BASINS & UTILITIES AS WELL AS A 7% BULKING WERE CONSIDERED IN THIS EARTHWORK QUANTITIES.

ADJUSTED CUT VOLUME = 167,100 CY  
 ADJUSTED FILL VOLUME = 167,100 CY  
 EXPORT = 0 CY

**PRESENT & PROPOSED USE:**

PRESENT: VACANT  
 PROPOSED: SINGLE FAMILY, OPEN SPACE

**PUBLIC UTILITIES & DISTRICTS**

SEWER - VALLECITOS WATER DISTRICT  
 WATER - OLIVENHEIM WATER DISTRICT  
 GAS & ELECTRIC - S.D.G.E.  
 TELEPHONE - AT&T  
 FIRE - COUNTY SERVICE AREA NO 107 ELFIN FOREST  
 SCHOOLS - UNIFIED SAN MARCOS

**GENERAL NOTES**

- CURRENT SAN DIEGO COUNTY ZONING: RURAL RESIDENTIAL (RR)
- CURRENT LAND USE DESIGNATION: C-1, VR-10.9 & SR 0.5
- GROSS AREA WITHIN SUBDIVISION BOUNDARY: 89.23 ACRES
- PROPOSED GRADING AREA: 31.35 AC
- TOTAL PROPOSED RESIDENTIAL LOTS: 76 EA (TOTAL AREA=18.27 AC)
- TOTAL PROPOSED STREET LOTS: 4 EA (TOTAL AREA=4.34 AC)
- TOTAL PROPOSED PARK LOT: 1 EA (TOTAL AREA=0.31 AC)
- TOTAL PROPOSED FOR WATER QUALITY LOTS: 4 EA (TOTAL AREA=2.40 AC)
- TOTAL OPEN SPACE LOTS (EXCLUDING WATER QUALITY LOTS): 8 EA (63.90 AC)
- TOTAL LOTS PROPOSED = 93 EA (NUMBERED LOTS = 76 EA, LETTERED LOTS = 17 EA)
- SMALLEST RESIDENTIAL LOT AREA: 7,899 SF / 0.18 AC (LOT 47)
- LARGEST RESIDENTIAL LOT AREA: 21,440.61 SF / 0.49 AC (LOT 67)
- ON-SITE NEW & EXISTING UTILITY DISTRIBUTION FACILITIES SHALL BE INSTALLED UNDERGROUND.
- AN ACCESS EASEMENT IS REQUESTED FROM THE COUNTY OF SAN DIEGO ACROSS THE APN 223-080-44. THIS ACCESS EASEMENT IS FOR THE IMPROVEMENT & INSTALLATION OF STREET "E" & PUBLIC UTILITIES INCLUDING THE TRAFFIC SIGNAL AT THE INTERSECTION OF SAN ELMO ROAD & PROPOSED STREET "E".

**SITE PLAN**  
 FOR COUNTY OF SAN DIEGO  
 TM 5643  
 76 LOT RESIDENTIAL SUBDIVISION

TITLE  
 SHEET 1 OF 4 SHEETS

**SURVEYOR OF WORK**

EXCEL ENGINEERING  
 440 STATE PLACE  
 ESCONCIDO, CA 92029  
 PHONE (760) 745-8118  
 FAX (760) 745-1890

MICHAEL D. LEVIN, P.L.S. NO. 6896



**ENGINEER OF WORK**

EXCEL ENGINEERING  
 440 STATE PLACE  
 ESCONCIDO, CA 92029  
 PHONE (760) 745-8118  
 FAX (760) 745-1890

ROBERT D. DENTINO, R.C.E. NO. 45629



**PRELIMINARY GRADING PLAN PREPARATION DATE**  
 NOVEMBER 2020

**FEMA INFORMATION**

PER THE FEMA MAP NO. 06073C1055G WITH AN EFFECTIVE DATE OF MAY 16, 2012, THE SITE IS IN ZONE X.

**BASIS OF BEARINGS**

THE BASIS OF BEARINGS FOR THIS PROJECT IS BETWEEN SURVEY CONTROL POINT #1089 "SM089" AND SURVEY CONTROL POINT #1110 "123W137" AS SHOWN ON RECORD OF SURVEY NO. 13928, RECORDED OCTOBER 1, 1992 AS FILE NO. 92-625379.

THE COMBINED FACTOR FOR THIS PROJECT IS BASED ON SURVEY CONTROL POINT #1089 "SM089", BEING 0.999922340 GROUND TO GRID.

IE: NORTH 25° 19' 13" EAST

**PROJECT BENCHMARK**

THE PROJECT BENCHMARK FOR THIS SURVEY IS SAN MARCOS SURVEY CONTROL POINT "SM089", A 2" BRASS DISK IN ROCK STAMPED "SM 089", AS SHOWN ON ROS 13928 AND ADJUSTED PER THE CITY OF SAN MARCOS BENCHMARK CONVERSION SHEETS, DATED SEPTEMBER 21, 2011.

ELEV: 973.370 DATUM: NAVD88

**STORM WATER MANAGEMENT PLAN**

PLEASE SEE THE SWMP PREPARED BY EXCEL ENGINEERING FOR THIS PROJECT & IS MADE A PART OF THE ENTITLEMENT PACKAGE.

**EXISTING EASEMENTS AS NOTED IN 1ST AMENDED PRELIMINARY TITLE REPORT ORDER NO. LJ-4663113 (06), UPDATED 10/14/2016**

- [01] AN EXISTING 100' WIDE EASEMENT FOR PUBLIC UTILITIES AND INCIDENTAL PURPOSES, GRANTED TO SAN DIEGO GAS AND ELECTRIC COMPANY PER DOCUMENT RECORDED OCTOBER 11, 1940 IN BOOK 1082, PAGE 293 OF OFFICIAL RECORDS.
- [02] AN EXISTING 50' WIDE EASEMENT FOR PUBLIC UTILITIES AND INCIDENTAL PURPOSES, GRANTED TO SAN DIEGO GAS AND ELECTRIC COMPANY PER DOCUMENT RECORDED NOVEMBER 3, 1965 AS INSTRUMENT NO. 199601 OF OFFICIAL RECORDS.
- [03] AN EASEMENT FOR ROAD AND UTILITY AND INCIDENTAL PURPOSES IN FAVOR OF JOHN A. THOMAS, JR. AND AVIS C. THOMAS, RECORDED FEBRUARY 28, 1964 AS INSTRUMENT NO. 37644 OF OFFICIAL RECORDS.
- [04] THE RIGHT TO EXTEND AND MAINTAIN DRAINAGE STRUCTURES AND EXCAVATION AND EMBANKMENT SLOPES BEYOND THE LIMITS OF THE RIGHT OF WAY GRANTED THEREIN WHERE REQUIRED FOR CONSTRUCTION AND MAINTENANCE GRANTED TO COUNTY OF SAN DIEGO, RECORDED JULY 14, 1978 AS INSTRUMENT NO. 78-294151 OF OFFICIAL RECORDS.
- [05] AN EASEMENT FOR INGRESS AND EGRESS AND INCIDENTAL PURPOSES IN FAVOR OF MORAD DEVELOPMENT COMPANY, RECORDED MARCH 3, 1971 AS INSTRUMENT NO. 41512 OF OFFICIAL RECORDS.
- [06] A 60 FOOT WIDE EASEMENT AND RIGHT-OF-WAY FOR INGRESS AND EGRESS FOR ROAD AND UTILITY PURPOSES, RECORDED MARCH 15, 1972 IN GRANT DEED FILE NO. 61527 OF OFFICIAL RECORDS.
- [07] AN EASEMENT FOR PUBLIC UTILITIES AND INCIDENTAL PURPOSES IN FAVOR OF SAN DIEGO GAS AND ELECTRIC COMPANY, RECORDED NOVEMBER 30, 1992 AS INSTRUMENT NO. 92-0764106 OF OFFICIAL RECORDS.
- [08] AN EASEMENT FOR DRAINAGE AND INCIDENTAL PURPOSES IN FAVOR OF THE CITY OF SAN MARCOS, RECORDED JUNE 6, 2003 AS INSTRUMENT NO. 03-0670400 OF OFFICIAL RECORDS.
- [09] AN EASEMENT FOR TEMPORARY SLOPE AND CONSTRUCTION AND INCIDENTAL PURPOSES IN FAVOR OF THE CITY OF SAN MARCOS, RECORDED JUNE 6, 2003 AS INSTRUMENT NO. 03-0670401 OF OFFICIAL RECORDS.
- [10] A 30' WIDE EASEMENT & RIGHT OF WAY IN FAVOR OF SD&E, RECORDED DECEMBER 24, 1992.

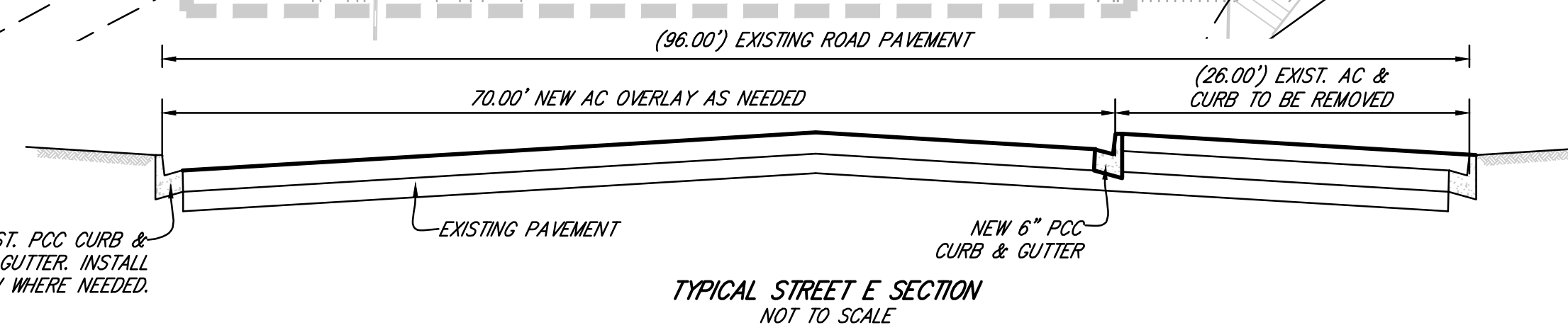
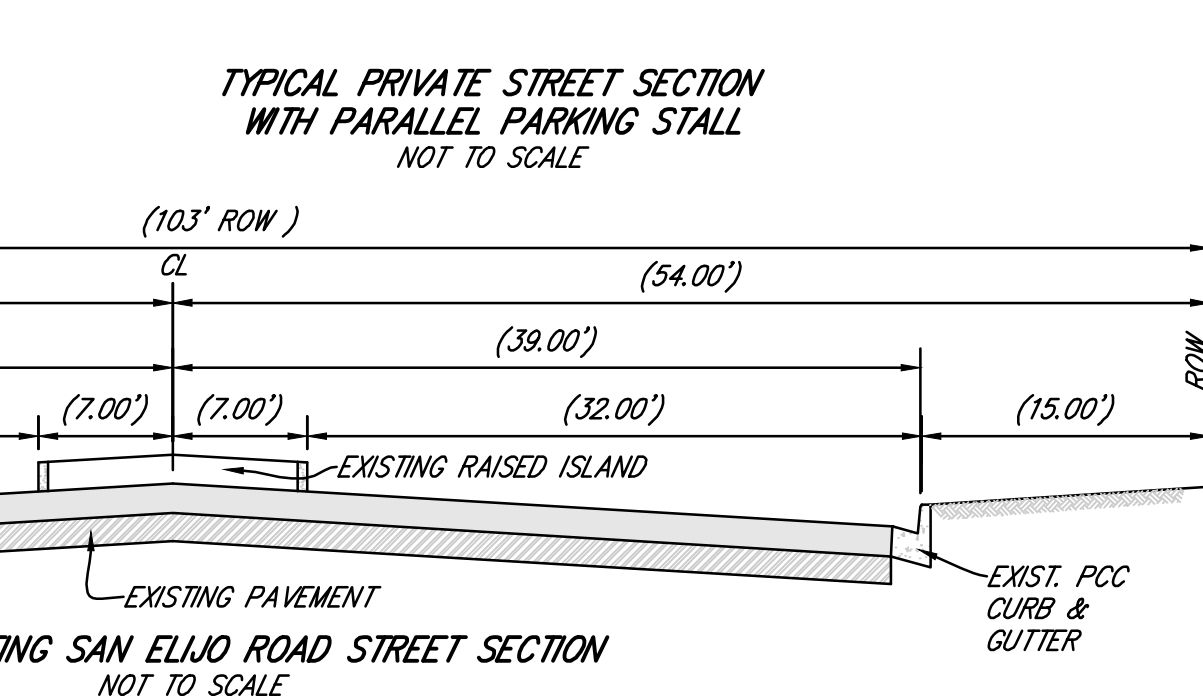
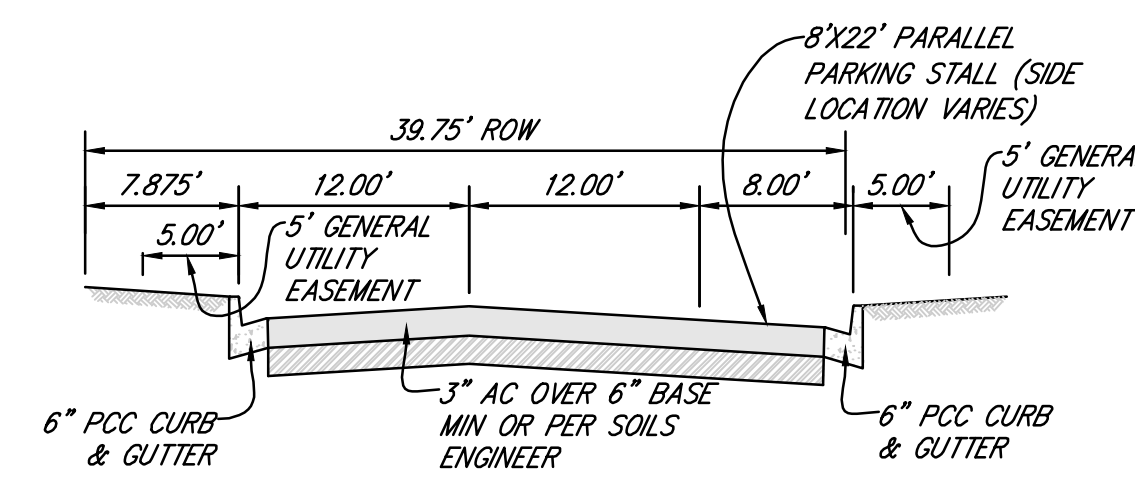
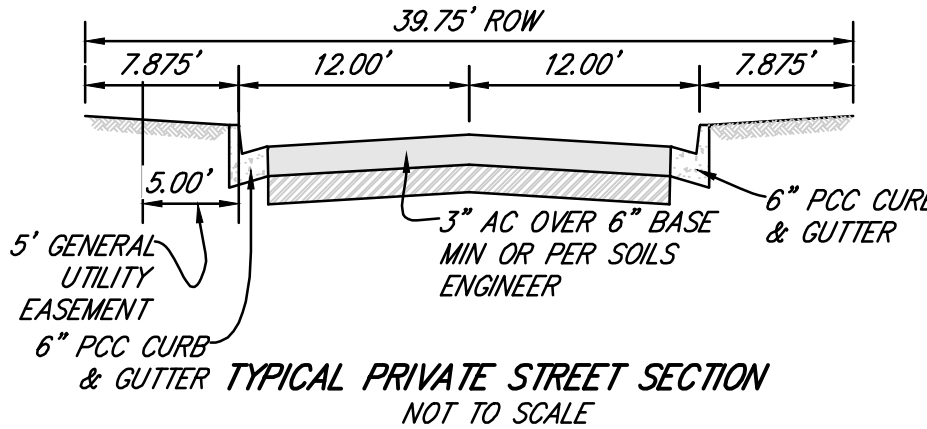

**NOTICE**  
 THE SUBJECT PROPERTY CONTAINS WETLANDS, A LAKE, A STREAM, AND/OR WATERS OF THE U.S. AND/OR STATE WHICH MAY BE SUBJECT TO REGULATION BY STATE AND/OR FEDERAL AGENCIES, INCLUDING, BUT NOT LIMITED TO, THE REGIONAL WATER QUALITY CONTROL BOARD, U.S. ARMY CORPS OF ENGINEERS AND THE CALIFORNIA DEPARTMENT OF FISH AND WILDLIFE. IT IS THE APPLICANT'S RESPONSIBILITY TO CONSULT WITH EACH AGENCY TO DETERMINE IF A PERMIT, AGREEMENT OR OTHER APPROVAL IS REQUIRED AND TO OBTAIN ALL NECESSARY PERMITS, AGREEMENTS OR APPROVALS BEFORE COMMENCING ANY ACTIVITY WHICH COULD IMPACT THE WETLANDS, LAKE, STREAM, AND/OR WATERS OF THE U.S. ON THE SUBJECT PROPERTY. THE AGENCY CONTACT INFORMATION IS PROVIDED BELOW.

U.S. ARMY CORPS OF ENGINEERS: 915 MILSHIRE BLVD., SUITE 1101, LOS ANGELES, CA 90017; (213) 452-3333; HTTP://WWW.USACE.ARMY.MIL/

REGIONAL WATER QUALITY CONTROL BOARD: 2375 NORTHSIDE DRIVE, SUITE 100, SAN DIEGO, CA 92108; RB2\_DREDGETILL@WATERBOARDS.CA.GOV.; HTTP://WWW.WATERBOARDS.CA.GOV./SANDIEGO/

CALIFORNIA DEPARTMENT OF FISH AND WILDLIFE: 3883 RUFFIN RD., SAN DIEGO, CA 92123; (619) 636-3160; ASKRS@WILDLIFE.CA.GOV. HTTP://WWW.DFG.CA.GOV/

NOTE \*  
 LOT "S" IS A BIOLOGICAL OPEN SPACE WITH THE EXCEPTION OF THE PORTION THAT IS WITHIN THE SD&E EASEMENT.

PORTION OF LOT S THAT IS BOTH SD&E EASEMENT & FIRE BUFFER OPEN SPACE. SEE NOTE \*

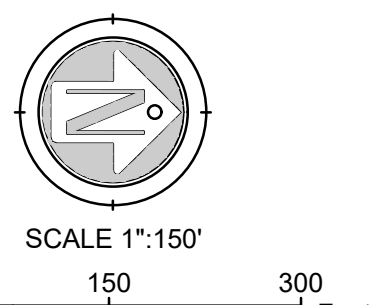

**SITE PLAN**  
FOR COUNTY OF SAN DIEGO  
TM 5643  
76 LOT RESIDENTIAL SUBDIVISION

**LOT SUMMARY**  
SHEET 2 OF 4 SHEETS

DENSITY BONUS CALCULATION BASED ON "LOW INCOME"			
LINE ID	LINE DESCRIPTION		REMARKS
1	BASE UNITS EA	64	64
2	RESERVED UNITS BASED ON "LOW INCOME"	10.00%	7 ROUND UP
3	MINIMUM BONUS OF THE BASE UNITS	20.00%	13 ROUND UP
4	TOTAL NUMBER OF UNITS		77
5	MARKET RATE UNITS		70
6	RESERVED UNITS		7
7	ANTICIPATED INCENTIVES: 1 ONLY		SIDE YARD SETBACKS
8	MAX NUMBER OF INCENTIVES	2	

BUILDING PLAN TABLE	
FLOOR PLAN	NO. OF UNITS
BUILDING 1	24
BUILDING 2	27
BUILDING 3	25
TOTAL UNITS	76

QUESTHAVEN SUBDIVISION - 76 UNITS LOT DATA TABLE						
LOT NO.	GROSS AREA (SF)	GROSS AREA (AC)	NET AREA (SF)	NET AREA (AC)	LOT USE	REMARKS
1	15,915.24	0.37	15,915.24	0.37	RESIDENTIAL	
2	12,776.89	0.29	12,776.89	0.29	RESIDENTIAL	
3	9,559.46	0.22	9,559.46	0.22	RESIDENTIAL	
4	11,993.44	0.28	11,993.44	0.28	RESIDENTIAL	
5	10,085.48	0.23	10,085.48	0.23	RESIDENTIAL	
6	8,955.98	0.21	8,955.98	0.21	RESIDENTIAL	
7	9,377.69	0.22	9,377.69	0.22	RESIDENTIAL	
8	10,949.04	0.25	10,949.04	0.25	RESIDENTIAL	
9	11,911.06	0.27	11,911.06	0.27	RESIDENTIAL	
10	12,220.86	0.28	12,220.86	0.28	RESIDENTIAL	
11	10,704.52	0.25	10,704.52	0.25	RESIDENTIAL	
12	8,423.35	0.19	8,423.35	0.19	RESIDENTIAL	
13	9,885.56	0.23	9,885.56	0.23	RESIDENTIAL	
14	8,835.26	0.20	8,835.26	0.20	RESIDENTIAL	
15	8,777.50	0.20	8,777.50	0.20	RESIDENTIAL	
16	8,804.98	0.20	8,804.98	0.20	RESIDENTIAL	
17	9,586.40	0.22	9,586.40	0.22	RESIDENTIAL	
18	11,158.05	0.26	11,158.05	0.26	RESIDENTIAL	
19	9,923.90	0.23	9,923.90	0.23	RESIDENTIAL	
20	9,924.50	0.23	9,924.50	0.23	RESIDENTIAL	
21	9,924.50	0.23	9,924.50	0.23	RESIDENTIAL	
22	9,924.50	0.23	9,924.50	0.23	RESIDENTIAL	
23	9,924.50	0.23	9,924.50	0.23	RESIDENTIAL	
24	9,924.50	0.23	9,924.50	0.23	RESIDENTIAL	
25	9,927.29	0.23	9,927.29	0.23	RESIDENTIAL	
26	9,367.98	0.22	9,367.98	0.22	RESIDENTIAL	
27	10,144.31	0.23	10,144.31	0.23	RESIDENTIAL	
28	10,144.31	0.23	10,144.31	0.23	RESIDENTIAL	
29	10,144.31	0.23	10,144.31	0.23	RESIDENTIAL	
30	10,144.31	0.23	10,144.31	0.23	RESIDENTIAL	
31	9,894.54	0.23	9,894.54	0.23	RESIDENTIAL	
32	9,000.00	0.21	9,000.00	0.21	RESIDENTIAL	
33	9,000.00	0.21	9,000.00	0.21	RESIDENTIAL	
34	10,500.00	0.24	10,500.00	0.24	RESIDENTIAL	
35	9,247.99	0.21	9,247.99	0.21	RESIDENTIAL	
36	9,292.83	0.21	9,292.83	0.21	RESIDENTIAL	
37	9,292.83	0.21	9,292.83	0.21	RESIDENTIAL	
38	9,292.83	0.21	9,292.83	0.21	RESIDENTIAL	
39	9,292.83	0.21	9,292.83	0.21	RESIDENTIAL	
40	9,292.83	0.21	9,292.83	0.21	RESIDENTIAL	
41	9,341.83	0.21	9,341.83	0.21	RESIDENTIAL	
42	11,984.56	0.28	11,984.56	0.28	RESIDENTIAL	
43	9,000.25	0.21	9,000.25	0.21	RESIDENTIAL	
44	9,000.00	0.21	9,000.00	0.21	RESIDENTIAL	
45	8,734.08	0.20	8,734.08	0.20	RESIDENTIAL	
46	16,229.65	0.37	16,229.65	0.37	RESIDENTIAL	
47	7,899.13	0.18	7,899.13	0.18	RESIDENTIAL	SMALLEST LOT
48	8,030.43	0.18	8,030.43	0.18	RESIDENTIAL	
49	8,258.23	0.19	8,258.23	0.19	RESIDENTIAL	
50	8,583.58	0.20	8,583.58	0.20	RESIDENTIAL	
51	10,608.53	0.24	10,608.53	0.24	RESIDENTIAL	
52	10,331.46	0.24	10,331.46	0.24	RESIDENTIAL	
53	8,666.22	0.20	8,666.22	0.20	RESIDENTIAL	
54	10,231.98	0.23	10,231.98	0.23	RESIDENTIAL	
55	9,715.97	0.22	9,715.97	0.22	RESIDENTIAL	
56	10,409.99	0.24	10,409.99	0.24	RESIDENTIAL	
57	12,507.91	0.29	12,507.91	0.29	RESIDENTIAL	
58	12,460.00	0.29	12,460.00	0.29	RESIDENTIAL	
59	11,917.52	0.27	11,917.52	0.27	RESIDENTIAL	
60	12,940.49	0.30	12,940.49	0.30	RESIDENTIAL	
61	13,666.51	0.31	13,666.51	0.31	RESIDENTIAL	
62	10,459.30	0.24	10,459.30	0.24	RESIDENTIAL	
63	10,438.12	0.24	10,438.12	0.24	RESIDENTIAL	
64	10,412.48	0.24	10,412.48	0.24	RESIDENTIAL	
65	10,096.71	0.23	10,096.71	0.23	RESIDENTIAL	
66	9,304.64	0.21	9,304.64	0.21	RESIDENTIAL	
67	16,032.27	0.37	16,032.27	0.37	RESIDENTIAL	LARGEST LOT
68	11,397.71	0.26	11,397.71	0.26	RESIDENTIAL	
69	9,770.10	0.22	9,770.10	0.22	RESIDENTIAL	
70	9,742.03	0.22	9,742.03	0.22	RESIDENTIAL	
71	9,321.80	0.21	9,321.80	0.21	RESIDENTIAL	
72	10,814.98	0.25	10,814.98	0.25	RESIDENTIAL	
73	12,302.60	0.28	12,302.60	0.28	RESIDENTIAL	
74	10,536.89	0.24	10,536.89	0.24	RESIDENTIAL	
75	10,536.89	0.24	10,536.89	0.24	RESIDENTIAL	
76	12,770.09	0.29	12,770.09	0.29	RESIDENTIAL	
A	13,699.68	0.31	13,699.68	0.31	PARK	
B	37,018.42	0.85	37,018.42	0.85	PRIVATE STREET	
C	97,488.19	2.24	97,488.19	2.24	PRIVATE STREET	
D	17,789.53	0.41	17,789.53	0.41	PRIVATE STREET	
E	36,897.43	0.85	36,897.43	0.85	PRIVATE STREET	
F	32,110.37	0.74	32,110.37	0.74	WATER QUALITY	
G	87,364.82	2.01	87,364.82	2.01	OPEN SPACE	PASSIVE RECREATIONAL PARK OPEN SPACE
H	19,798.48	0.45	19,798.48	0.45	OPEN SPACE	SLOPE OPEN SPACE
J	5,005.10	0.11	5,005.10	0.11	WATER QUALITY	
K	38,685.71	0.89	38,685.71	0.89	WATER QUALITY	
L	28,458.07	0.65	28,458.07	0.65	WATER QUALITY	
N	18,423.90	0.42	18,423.90	0.42	OPEN SPACE	SLOPE OPEN SPACE
P	89,273.76	2.05	89,273.76	2.05	OPEN SPACE	SDG&E EASEMENT & FIRE BUFFER OPEN SPACE
Q	82,517.05	1.89	82,517.05	1.89	OPEN SPACE	SDG&E EASEMENT & FIRE BUFFER OPEN SPACE
R	167,599.45	3.85	167,599.45	3.85	OPEN SPACE	FIRE BUFFER OPEN SPACE
S	2,314,336.49	53.13	2,314,336.49	53.13	OPEN SPACE	BIOLOGICAL OPEN SPACE W/ EXCEPTION OF THE SDG&E EASEMENT
T	12,550.26	0.29	12,550.26	0.29	OPEN SPACE	SLOPE OPEN SPACE
TOTAL	3,886,917.99	89.23	3,886,917.99	89.23		

NOTE \*  
LOT "S" IS A BIOLOGICAL OPEN SPACE WITH THE EXCEPTION OF THE PORTION THAT IS WITHIN THE SDG&E EASEMENT.

PORTION OF LOT S THAT IS BOTH SDG&E EASEMENT & FIRE BUFFER OPEN SPACE. SEE NOTE \*

NOTE: BLDG PLANS SHOWN HEREON MAY NOT BE THE FINAL DESIGN THAT WILL BE USED DURING THE CONSTRUCTION PERMIT PHASE.



PROPOSED BUILDING FLOOR PLANS

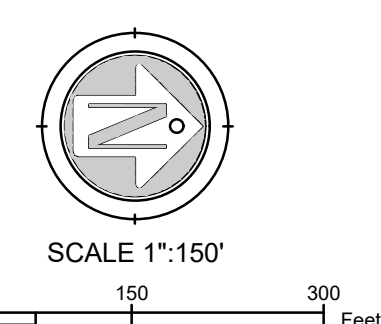

K:\19\190208\Engineering\TM\TM04\stephan\190208\_stephan\_lot\_info.dwg 2/21/2024 12:56 PM ORIGINAL PLOT SIZE

**SITE PLAN**  
FOR COUNTY OF SAN DIEGO  
TM 5643  
76 LOT RESIDENTIAL SUBDIVISION

SITEPLAN  
SHEET 3 OF 4 SHEETS

- CONSTRUCTION NOTES**
- SD-1 INSTALL BROWDNITCH
  - SD-2 INSTALL INLET/CLEANOUT
  - SD-3 INSTALL STORM DRAIN PIPE
  - SD-4 INSTALL HEADWALL
  - SD-5 INSTALL RIPRAP
  - W-1 INSTALL 8" WATER MAIN
  - W-2 INSTALL FIRE HYDRANT
  - S-1 INSTALL 8" SEWER MAIN
  - S-2 INSTALL SEWER MANHOLE/C.O.
  - WO-1 WATER QUALITY BASIN
  - WO-2 RUNOFF SPREADER DITCH WITH OUTLET AT REGULAR INTERVAL OR EQUIVALENT

**LEGEND**

BOUNDARY LINE	---
RIGHT OF WAY LINE	---FW---
PARCEL LOT LINE	---
PCC CURB	---
PCC CURB & GUTTER	---
SEWER LINE	S S
WATER LINE	W W
FIRE LINE	F F
FIRE HYDRANT	⊕
WATER SERVICE LATERAL	⊕
SEWER SERVICE LATERAL	⊕
DOUBLE DETECTOR CHECK VALVE	⊕
STORM DRAIN INLETS / CLEANOUTS	⊕
HEADWALL	⊕
RIPRAP	⊕
EXIST. TOPO MAJOR CONTOUR	---
EXIST. TOPO MINOR CONTOUR	---
PROPOSED TOPO MAJOR CONTOUR	---
PROPOSED TOPO MINOR CONTOUR	---
ACCESS RELINQUISHED SIDE	---
PROPOSED DRIVEWAY LOCATION WILL BE FINALIZED DURING THE PRECISE GP PROCESS.	---
SDG&E OVERHEAD LINES	---
NEW WATER MAIN TO CONNECT TO THE EXIST. OLIVENHAIN 10" PVC-2 WATER LINE HERE.	---
EXISTING SCALES	---

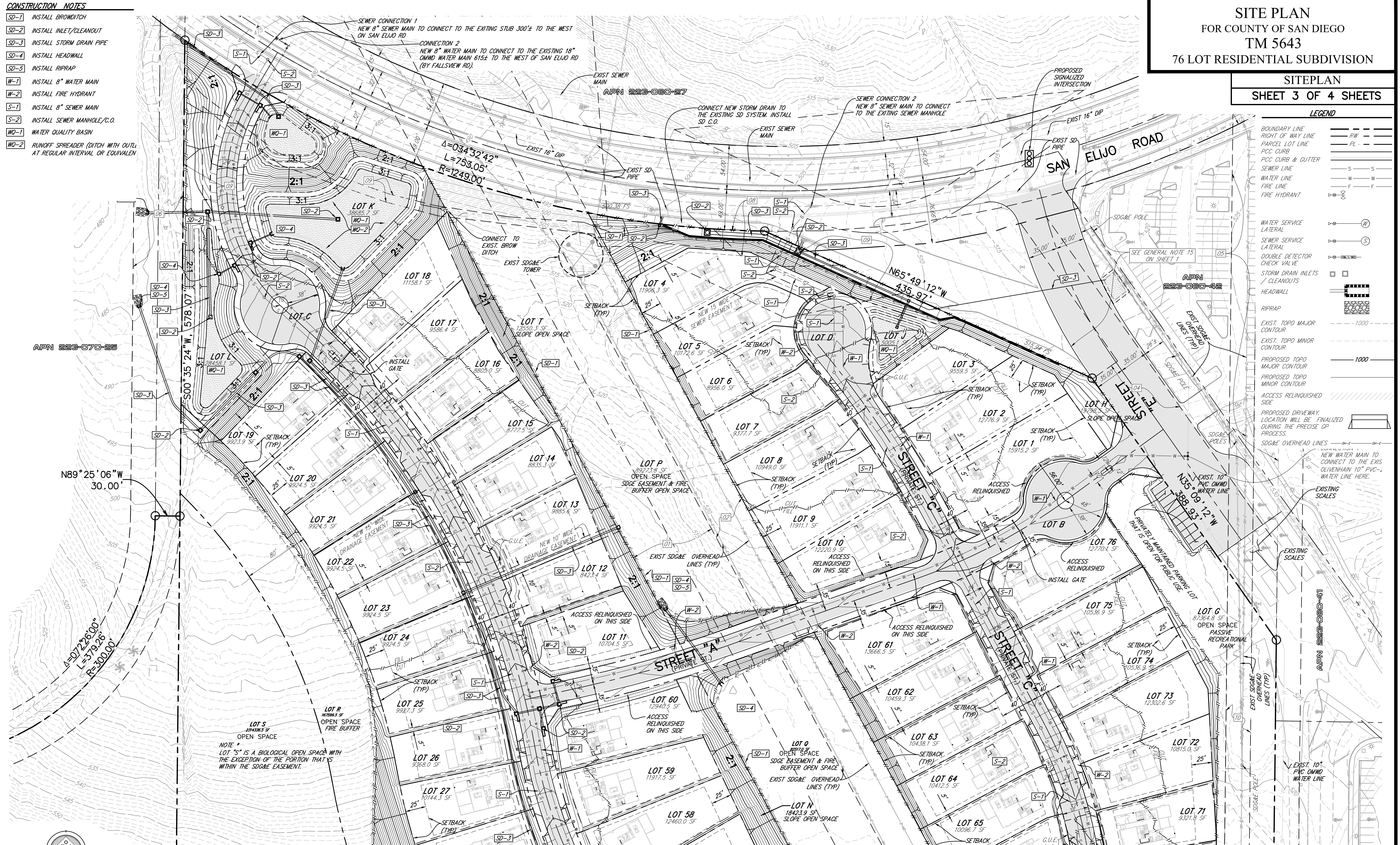

MATCHLINE SEE SHEET 4 FOR CONTINUATION

K:\19\190208\Engineering\TM\TM04\stephan\190208\_stephan.dwg 2/21/2024 12:57 PM ORIGINAL PLOT SIZE: 11.00000000

MATCHLINE SEE SHEET 3 FOR CONTINUATION

**SITE PLAN**  
 FOR COUNTY OF SAN DIEGO  
**TM 5643**  
**76 LOT RESIDENTIAL SUBDIVISION**

**SITEPLAN**  
**SHEET 4 OF 4 SHEETS**



**LEGEND**

BOUNDARY LINE	---
RIGHT OF WAY LINE	— RW —
PARCEL LOT LINE	— PL —
PCC CURB	—
PCC CURB & GUTTER	—
SEWER LINE	S — S
WATER LINE	W — W
FIRE LINE	F — F
FIRE HYDRANT	⊕
WATER SERVICE LATERAL	⊕ (W)
SEWER SERVICE LATERAL	⊕ (S)
DOUBLE DETECTOR CHECK VALVE	⊕
STORM DRAIN INLETS / CLEANOUTS	⊕
HEADWALL	▬
RIPRAP	▨
EXIST. TOPO MAJOR CONTOUR	--- 1000 ---
EXIST. TOPO MINOR CONTOUR	--- 1000 ---
PROPOSED TOPO MAJOR CONTOUR	— 1000 —
PROPOSED TOPO MINOR CONTOUR	— 1000 —
ACCESS RELINQUISHED SIDE	▨
PROPOSED DRIVEWAY LOCATION WILL BE FINALIZED DURING THE PRECISE GP PROCESS.	▬
SDG&E OVERHEAD LINES	— o — o —

**CONSTRUCTION NOTES**

- SD-1 INSTALL BROWDITCH
- SD-2 INSTALL INLET/CLEANOUT
- SD-3 INSTALL STORM DRAIN PIPE
- SD-4 INSTALL HEADWALL
- SD-5 INSTALL RIPRAP
- W-1 INSTALL 8" WATER MAIN
- W-2 INSTALL FIRE HYDRANT
- S-1 INSTALL 8" SEWER MAIN
- S-2 INSTALL SEWER MANHOLE/C.O.
- WO-1 WATER QUALITY BASIN
- WO-2 RUNOFF SPREADER (DITCH WITH OUTLETS AT REGULAR INTERVAL OR EQUIVALENT)

NOTE: LOT "S" IS A BIOLOGICAL OPEN SPACE WITH THE EXCEPTION OF THE PORTION THAT IS WITHIN THE SDG&E EASEMENT.

APN 223-080-40

