

GENERAL NOTES

- CURRENT SAN DIEGO COUNTY ZONING: RURAL RESIDENTIAL (RR)
- CURRENT LAND USE DESIGNATION: C-1, VR-10.9 & SR 0.5
- GROSS AREA WITHIN SUBDIVISION BOUNDARY: 89.23 ACRES
- PROPOSED GRADING AREA: 31.35 AC
- TOTAL PROPOSED RESIDENTIAL LOTS: 76 EA (TOTAL AREA=18.27 AC)
- TOTAL PROPOSED STREET LOTS: 4 EA (TOTAL AREA=4.34 AC)
- TOTAL PROPOSED PARK LOT: 1 EA (TOTAL AREA=0.31 AC)
- TOTAL PROPOSED FOR WATER QUALITY LOTS: 4 EA (TOTAL AREA=2.40 AC)
- TOTAL OPEN SPACE LOTS (EXCLUDING WATER QUALITY LOTS): 8 EA (63.90 AC)
- TOTAL LOTS PROPOSED = 93 EA (NUMBERED LOTS = 76 EA, LETTERED LOTS = 17 EA)
- SMALLEST RESIDENTIAL LOT AREA: 7,899 SF / 0.18 AC (LOT 47)
- LARGEST RESIDENTIAL LOT AREA: 21,440.61 SF / 0.49 AC (LOT 67)
- ON-SITE NEW & EXISTING UTILITY DISTRIBUTION FACILITIES SHALL BE INSTALLED UNDERGROUND.
- AN ACCESS EASEMENT IS REQUESTED FROM THE COUNTY OF SAN DIEGO ACROSS THE APN 223-080-44. THIS ACCESS EASEMENT IS FOR THE IMPROVEMENT & INSTALLATION OF STREET "E" & PUBLIC UTILITIES INCLUDING THE TRAFFIC SIGNAL AT THE INTERSECTION OF SAN ELIJO ROAD & PROPOSED STREET "E".

$\Delta=105^{\circ}41'20''$
 $L=184.46'$
 $R=100.00'$

INDEX SHEET
 SHEET 1 - TITLE
 SHEET 2 - LOT SUMMARY
 SHEET 3 - TENTATIVE MAP
 SHEET 4 - TENTATIVE MAP

APNS: 223-070-07 & 08		RR
USE REGULATIONS		RR
ANIMAL REGULATIONS		V
DEVELOPMENT REGULATIONS		
DENSITY	-	-
LOT SIZE	2 AC	-
BUILDING TYPE	C	-
MAXIMUM FLOOR AREA	-	-
HEIGHT	G	-
LOT COVERAGE	-	-
SETBACK	B	-
OPEN SPACE	-	-
SPECIAL AREA REGULATIONS		-

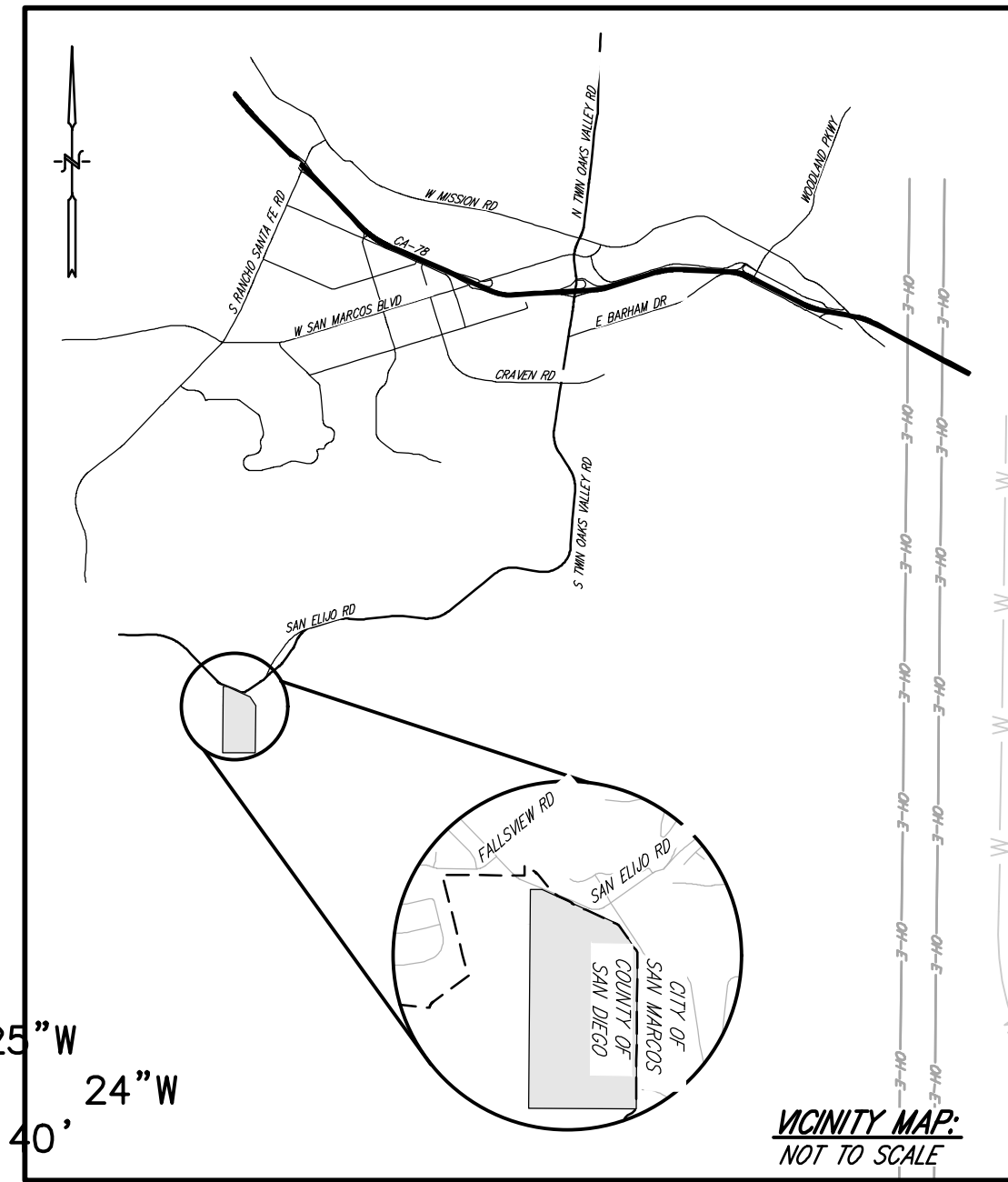

OWNER'S CERTIFICATE

I HEREBY CERTIFY THAT I AM THE RECORD OWNER OF THE PROPERTY SHOWN ON THIS TENTATIVE SUBDIVISION MAP AND THAT SAID MAP SHOWS MY ENTIRE CONTIGUOUS OWNERSHIP. I UNDERSTAND THAT THE PROPERTY IS CONSIDERED CONTIGUOUS EVEN IF IT IS SEPARATED BY ROADS, STREETS, UTILITY EASEMENTS OR RAILROAD RIGHTS OF WAY.

OWNER: OR QUESTHAVEN, LLC
 DATE: February 21, 2024

OWNER / DEVELOPER: OR QUESTHAVEN, LLC

DANNY GABRIEL, PRESIDENT
 DATE: February 21, 2024

DEVELOPER ADDRESS

444 WEST BEECH STREET
 SUITE 300
 SAN DIEGO, CA 92101

EARTHWORK QUANTITIES:

THE PRISMATICAL VOLUME METHOD WAS USED TO CALCULATE THE VALUES SHOWN HEREON. SECTIONS OF STREETS, BIO BASINS & UTILITIES AS WELL AS A 7% BULKING WERE CONSIDERED IN THIS EARTHWORK QUANTITIES.

ADJUSTED CUT VOLUME = 167,100 CY
 ADJUSTED FILL VOLUME = 167,100 CY
 EXPORT = 0 CY

PRESENT & PROPOSED USE:

PRESENT: VACANT
 PROPOSED: SINGLE FAMILY, OPEN SPACE

PUBLIC UTILITIES & DISTRICTS:

SEWER - VALLECITOS WATER DISTRICT
 WATER - OLIVENHEIM WATER DISTRICT
 GAS & ELECTRIC - S.D.G.E.
 TELEPHONE - AT&T
 FIRE - COUNTY SERVICE AREA NO. 107 ELFIN FOREST
 SCHOOLS - UNIFIED SAN MARCOS

ACCESS:

THE ACCESS TO THIS PROJECT IS VIA THE PROPOSED PRIVATE ROADS "A", "B", "C", "D", & "E". ROADS "D" & "E" CONNECTS TO THE EXISTING PUBLIC SAN ELIJO ROAD.

ASSESSOR'S PARCEL NUMBERS:

223-080-46-00, 223-070-07-00 & 223-070-08-00

LEGAL DESCRIPTION:

THE WEST HALF OF THE NORTHWEST QUARTER OF SECTION 33, TOWNSHIP 12 SOUTH, RANGE 3 WEST, SAN BERNARDINO MERIDIAN, IN THE COUNTY OF SAN DIEGO, STATE OF CALIFORNIA, ACCORDING TO THE OFFICIAL PLAT THEREOF. EXCEPTING THEREFROM THE WESTERLY 100 FEET OF THE NORTHERLY 100 FEET THEREOF.

ALSO EXCEPTING THEREFROM ALL THAT PORTION OF THE WEST HALF OF THE NORTHWEST QUARTER OF SECTION 33, TOWNSHIP 12, RANGE 3 WEST, SAN BERNARDINO MERIDIAN, IN THE COUNTY OF SAN DIEGO, STATE OF CALIFORNIA.

ALSO EXCEPTING THEREFROM THAT PORTION DESCRIBED IN GRANT DEED TO THE CITY OF SAN MARCOS RECORDED JUNE 6, 2003, AS INSTRUMENT NO. 2003399 OF OFFICIAL RECORDS.

SOURCE OF TOPOGRAPHY:

TOPOGRAPHY SHOWN ON THESE PLANS WAS GENERATED BY PHOTOGAMETRIC METHODS FROM INFORMATION GATHERED ON 10-11-2013 BY AEROTECH MAPPING. TOPOGRAPHY SHOWN HEREON CONFORMS TO NATIONAL MAP ACCURACY STANDARDS.

COUNTY OF SAN DIEGO
 TM 5643
 76 LOT RESIDENTIAL SUBDIVISION

TITLE
 SHEET 1 OF 4 SHEETS

SURVEYOR OF WORK

EXCEL ENGINEERING
 440 STATE PLACE
 ESCONDIDO, CA 92029
 PHONE (760) 745-8118
 FAX (760) 745-1890

MICHAEL D. LEVIN, P.L.S. NO. 6896

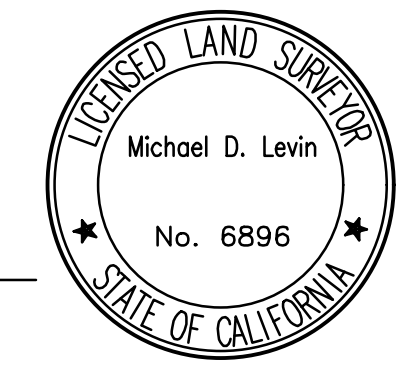

ENGINEER OF WORK

EXCEL ENGINEERING
 440 STATE PLACE
 ESCONDIDO, CA 92029
 PHONE (760) 745-8118
 FAX (760) 745-1890

ROBERT D. DENTINO, R.C.E. NO. 45629



FEMA INFORMATION:

PER THE FEMA MAP NO. 06023C10556 WITH AN EFFECTIVE DATE OF MAY 16, 2012, THE SITE IS IN ZONE X.

TENTATIVE MAP PREPARATION DATE:

AUGUST 2021

BASIS OF BEARINGS:

THE BASIS OF BEARINGS FOR THIS PROJECT IS BETWEEN SURVEY CONTROL POINT #1089 "SM089" AND SURVEY CONTROL POINT #1110 "123W137" AS SHOWN ON RECORD OF SURVEY NO. 13928, RECORDED OCTOBER 1, 1992 AS FILE NO. 92-625379.

THE COMBINED FACTOR FOR THIS PROJECT IS BASED ON SURVEY CONTROL POINT #1089 "SM089", BEING 0.999922340 GROUND TO GRID.

IE: NORTH 25° 19' 13" EAST

PROJECT BENCHMARK:

THE PROJECT BENCHMARK FOR THIS SURVEY IS SAN MARCOS SURVEY CONTROL POINT "SM089", A 2" BRASS DISK IN ROCK STAMPED "SM 089", AS SHOWN ON ROS 13928 AND ADJUSTED PER THE CITY OF SAN MARCOS BENCHMARK CONVERSION SHEETS, DATED SEPTEMBER 21, 2011.

ELEV: 973.370 DATUM: NAVD88

STORM WATER MANAGEMENT PLAN:

PLEASE SEE THE SWMP PREPARED BY EXCEL ENGINEERING FOR THIS PROJECT & IS MADE A PART OF THE ENTITLEMENT PACKAGE.

EASEMENT NOTE:

EASEMENTS OF RECORD NOT SHOWN HEREON SHALL BE HONORED, ABANDONED AND / OR RELOCATED TO THE SATISFACTION OF ALL INTERESTED PARTIES. PUBLIC UTILITY EASEMENTS NECESSARY TO SERVE THIS PROJECT WILL BE COORDINATED WITH THE SERVING UTILITY COMPANY.

EXISTING EASEMENTS AS NOTED IN 1ST AMENDED PRELIMINARY TITLE REPORT ORDER NO. LJ-4663113 (06), UPDATED 10/14/2016

- AN EXISTING 100' WIDE EASEMENT FOR PUBLIC UTILITIES AND INCIDENTAL PURPOSES, GRANTED TO SAN DIEGO GAS AND ELECTRIC COMPANY PER DOCUMENT RECORDED OCTOBER 11, 1940 IN BOOK 1082, PAGE 293 OF OFFICIAL RECORDS.
- AN EXISTING 50' WIDE EASEMENT FOR PUBLIC UTILITIES AND INCIDENTAL PURPOSES, GRANTED TO SAN DIEGO GAS AND ELECTRIC COMPANY PER DOCUMENT RECORDED NOVEMBER 3, 1965 AS INSTRUMENT NO. 199601 OF OFFICIAL RECORDS.
- AN EASEMENT FOR ROAD AND UTILITY AND INCIDENTAL PURPOSES IN FAVOR OF JOHN A. THOMAS, JR AND AVIS C. THOMAS, RECORDED FEBRUARY 28, 1964 AS INSTRUMENT NO. 37644 OF OFFICIAL RECORDS.
- THE RIGHT TO EXTEND AND MAINTAIN DRAINAGE STRUCTURES AND EXCAVATION AND EMBANKMENT SLOPES BEYOND THE LIMITS OF THE RIGHT OF WAY GRANTED THEREIN WHERE REQUIRED FOR CONSTRUCTION AND MAINTENANCE GRANTED TO COUNTY OF SAN DIEGO, RECORDED JULY 14, 1978 AS INSTRUMENT NO. 78-294151 OF OFFICIAL RECORDS.
- AN EASEMENT FOR INGRESS AND EGRESS AND INCIDENTAL PURPOSES IN FAVOR OF NORAD DEVELOPMENT COMPANY, RECORDED MARCH 3, 1971 AS INSTRUMENT NO. 41512 OF OFFICIAL RECORDS.
- A 60 FOOT WIDE EASEMENT AND RIGHT-OF-WAY FOR INGRESS AND EGRESS FOR ROAD AND UTILITY PURPOSES, RECORDED MARCH 15, 1972 IN GRANT DEED FILE NO. 61527 OF OFFICIAL RECORDS.
- AN EASEMENT FOR PUBLIC UTILITIES AND INCIDENTAL PURPOSES IN FAVOR OF SAN DIEGO GAS AND ELECTRIC COMPANY, RECORDED NOVEMBER 30, 1992 AS INSTRUMENT NO. 92-0764106 OF OFFICIAL RECORDS.
- AN EASEMENT FOR DRAINAGE AND INCIDENTAL PURPOSES IN FAVOR OF THE CITY OF SAN MARCOS, RECORDED JUNE 6, 2003 AS INSTRUMENT NO. 03-0670400 OF OFFICIAL RECORDS.
- AN EASEMENT FOR TEMPORARY SLOPE AND CONSTRUCTION AND INCIDENTAL PURPOSES IN FAVOR OF THE CITY OF SAN MARCOS, RECORDED JUNE 6, 2003 AS INSTRUMENT NO. 03-0670401 OF OFFICIAL RECORDS.
- A 30' WIDE EASEMENT & RIGHT OF WAY IN FAVOR OF SD&GE, RECORDED DECEMBER 24, 1992.

APN: 223-080-46 (NORTHERN PORTION)

APN: 223-080-46 (NORTHERN PORTION)		RR
USE REGULATIONS		RR
ANIMAL REGULATIONS		V
DEVELOPMENT REGULATIONS		
DENSITY	-	-
LOT SIZE	1 AC	-
BUILDING TYPE	C	-
MAXIMUM FLOOR AREA	-	-
HEIGHT	G	-
LOT COVERAGE	-	-
SETBACK	B	-
OPEN SPACE	-	-
SPECIAL AREA REGULATIONS		-

APN: 223-080-46 (SOUTHERN PORTION)

APN: 223-080-46 (SOUTHERN PORTION)		SBO
USE REGULATIONS		SBO
ANIMAL REGULATIONS		V
DEVELOPMENT REGULATIONS		
DENSITY	-	-
LOT SIZE	2 AC	-
BUILDING TYPE	C	-
MAXIMUM FLOOR AREA	-	-
HEIGHT	G	-
LOT COVERAGE	-	-
SETBACK	B	-
OPEN SPACE	-	-
SPECIAL AREA REGULATIONS		-

NOTE: LOT "S" IS A BIOLOGICAL OPEN SPACE WITH THE EXCEPTION OF THE PORTION THAT IS WITHIN THE SD&GE EASEMENT.

PORTION OF LOT "S" THAT IS BOTH SD&GE EASEMENT & FIRE BUFFER OPEN SPACE - SEE NOTE *

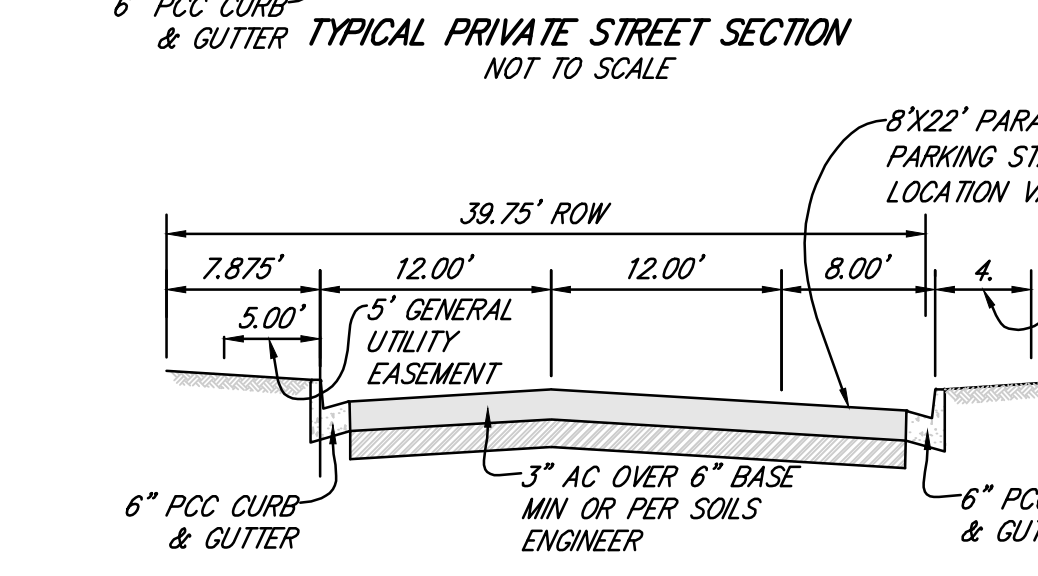
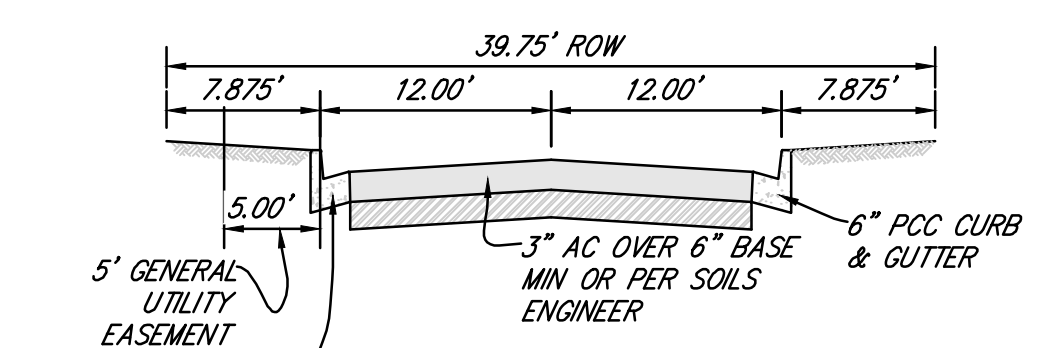
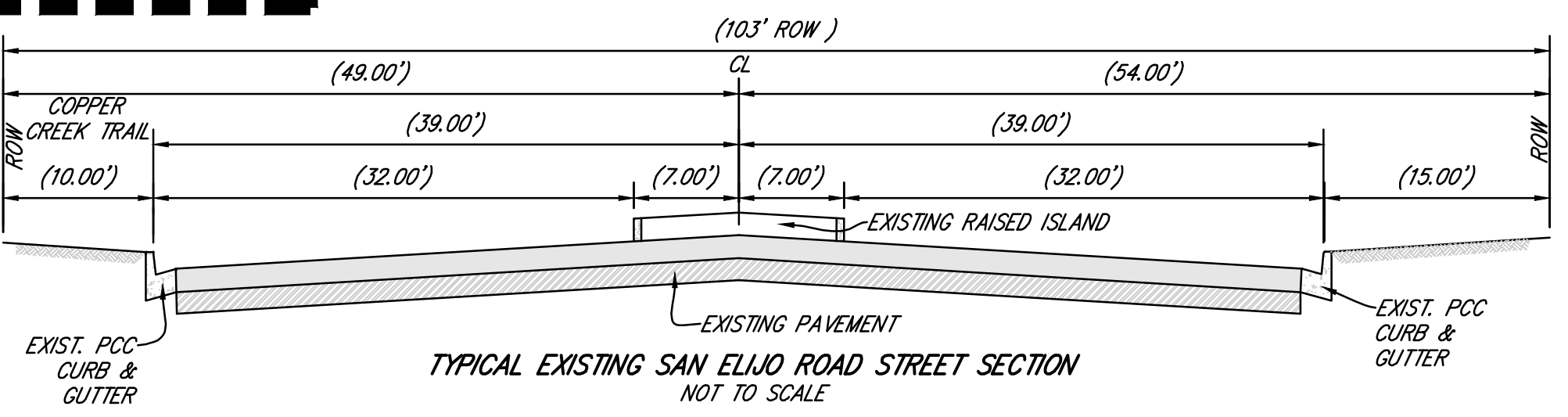
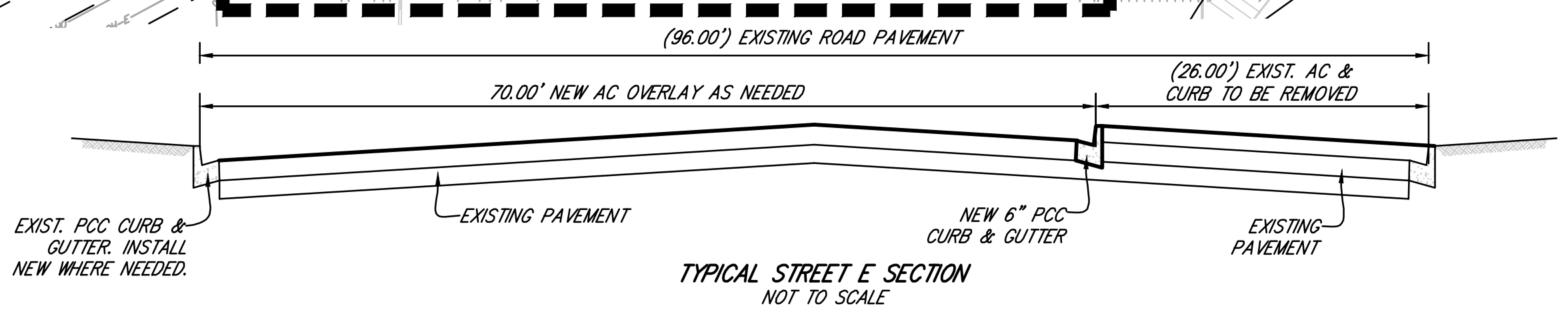
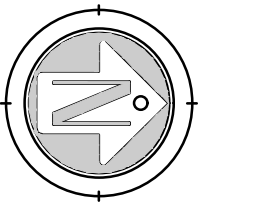

K:\19\190238\Engineering\TM\TM04\TM\190238_TM_title.dwg 2/21/2024 1:11 PM ORIGINAL PLOT SIZE: 11x17

DENSITY BONUS CALCULATION BASED ON "LOW INCOME"

LINE ID	LINE DESCRIPTION		REMARKS
1	BASE UNITS EA	64	64
2	RESERVED UNITS BASED ON "LOW INCOME"	10.00%	7 ROUND UP
3	MINIMUM BONUS OF THE BASE UNITS	20.00%	13 ROUND UP
4	TOTAL NUMBER OF UNITS		77
5	MARKET RATE UNITS		70
6	RESERVED UNITS		7
7	ANTICIPATED INCENTIVES: 1 ONLY		SIDE YARD SETBACKS
8	MAX NUMBER OF INCENTIVES	2	

QUESTHAVEN SUBDIVISION - 76 UNITS LOT DATA TABLE

LOT NO.	GROSS AREA (SF)	GROSS AREA (AC)	NET AREA (SF)	NET AREA (AC)	LOT USE	REMARKS
1	15,915.24	0.37	15,915.24	0.37	RESIDENTIAL	
2	12,776.89	0.29	12,776.89	0.29	RESIDENTIAL	
3	9,559.46	0.22	9,559.46	0.22	RESIDENTIAL	
4	11,993.44	0.28	11,993.44	0.28	RESIDENTIAL	
5	10,085.48	0.23	10,085.48	0.23	RESIDENTIAL	
6	8,955.98	0.21	8,955.98	0.21	RESIDENTIAL	
7	9,377.69	0.22	9,377.69	0.22	RESIDENTIAL	
8	10,949.04	0.25	10,949.04	0.25	RESIDENTIAL	
9	11,911.06	0.27	11,911.06	0.27	RESIDENTIAL	
10	12,220.86	0.28	12,220.86	0.28	RESIDENTIAL	
11	10,704.52	0.25	10,704.52	0.25	RESIDENTIAL	
12	8,423.35	0.19	8,423.35	0.19	RESIDENTIAL	
13	9,885.56	0.23	9,885.56	0.23	RESIDENTIAL	
14	8,835.26	0.20	8,835.26	0.20	RESIDENTIAL	
15	8,777.50	0.20	8,777.50	0.20	RESIDENTIAL	
16	8,804.98	0.20	8,804.98	0.20	RESIDENTIAL	
17	9,586.40	0.22	9,586.40	0.22	RESIDENTIAL	
18	11,158.05	0.26	11,158.05	0.26	RESIDENTIAL	
19	9,923.90	0.23	9,923.90	0.23	RESIDENTIAL	
20	9,924.50	0.23	9,924.50	0.23	RESIDENTIAL	
21	9,924.50	0.23	9,924.50	0.23	RESIDENTIAL	
22	9,924.50	0.23	9,924.50	0.23	RESIDENTIAL	
23	9,924.50	0.23	9,924.50	0.23	RESIDENTIAL	
24	9,924.50	0.23	9,924.50	0.23	RESIDENTIAL	
25	9,927.29	0.23	9,927.29	0.23	RESIDENTIAL	
26	9,367.98	0.22	9,367.98	0.22	RESIDENTIAL	
27	10,144.31	0.23	10,144.31	0.23	RESIDENTIAL	
28	10,144.31	0.23	10,144.31	0.23	RESIDENTIAL	
29	10,144.31	0.23	10,144.31	0.23	RESIDENTIAL	
30	10,144.31	0.23	10,144.31	0.23	RESIDENTIAL	
31	9,894.54	0.23	9,894.54	0.23	RESIDENTIAL	
32	9,000.00	0.21	9,000.00	0.21	RESIDENTIAL	
33	9,000.00	0.21	9,000.00	0.21	RESIDENTIAL	
34	10,500.00	0.24	10,500.00	0.24	RESIDENTIAL	
35	9,247.99	0.21	9,247.99	0.21	RESIDENTIAL	
36	9,292.83	0.21	9,292.83	0.21	RESIDENTIAL	
37	9,292.83	0.21	9,292.83	0.21	RESIDENTIAL	
38	9,292.83	0.21	9,292.83	0.21	RESIDENTIAL	
39	9,292.83	0.21	9,292.83	0.21	RESIDENTIAL	
40	9,292.83	0.21	9,292.83	0.21	RESIDENTIAL	
41	9,341.83	0.21	9,341.83	0.21	RESIDENTIAL	
42	11,984.56	0.28	11,984.56	0.28	RESIDENTIAL	
43	9,000.25	0.21	9,000.25	0.21	RESIDENTIAL	
44	9,000.00	0.21	9,000.00	0.21	RESIDENTIAL	
45	8,734.08	0.20	8,734.08	0.20	RESIDENTIAL	
46	16,229.65	0.37	16,229.65	0.37	RESIDENTIAL	
47	7,899.13	0.18	7,899.13	0.18	RESIDENTIAL	SMALLEST LOT
48	8,030.43	0.18	8,030.43	0.18	RESIDENTIAL	
49	8,258.23	0.19	8,258.23	0.19	RESIDENTIAL	
50	8,583.58	0.20	8,583.58	0.20	RESIDENTIAL	
51	10,608.53	0.24	10,608.53	0.24	RESIDENTIAL	
52	10,331.46	0.24	10,331.46	0.24	RESIDENTIAL	
53	8,666.22	0.20	8,666.22	0.20	RESIDENTIAL	
54	10,231.98	0.23	10,231.98	0.23	RESIDENTIAL	
55	9,715.97	0.22	9,715.97	0.22	RESIDENTIAL	
56	10,409.99	0.24	10,409.99	0.24	RESIDENTIAL	
57	12,507.91	0.29	12,507.91	0.29	RESIDENTIAL	
58	12,460.00	0.29	12,460.00	0.29	RESIDENTIAL	
59	11,917.52	0.27	11,917.52	0.27	RESIDENTIAL	
60	12,940.49	0.30	12,940.49	0.30	RESIDENTIAL	
61	13,666.51	0.31	13,666.51	0.31	RESIDENTIAL	
62	10,459.30	0.24	10,459.30	0.24	RESIDENTIAL	
63	10,438.12	0.24	10,438.12	0.24	RESIDENTIAL	
64	10,412.48	0.24	10,412.48	0.24	RESIDENTIAL	
65	10,096.71	0.23	10,096.71	0.23	RESIDENTIAL	
66	9,304.64	0.21	9,304.64	0.21	RESIDENTIAL	
67	16,032.27	0.37	16,032.27	0.37	RESIDENTIAL	LARGEST LOT
68	11,397.71	0.26	11,397.71	0.26	RESIDENTIAL	
69	9,770.10	0.22	9,770.10	0.22	RESIDENTIAL	
70	9,742.03	0.22	9,742.03	0.22	RESIDENTIAL	
71	9,321.80	0.21	9,321.80	0.21	RESIDENTIAL	
72	10,814.98	0.25	10,814.98	0.25	RESIDENTIAL	
73	12,302.60	0.28	12,302.60	0.28	RESIDENTIAL	
74	10,536.89	0.24	10,536.89	0.24	RESIDENTIAL	
75	10,536.89	0.24	10,536.89	0.24	RESIDENTIAL	
76	12,770.09	0.29	12,770.09	0.29	RESIDENTIAL	
A	13,699.68	0.31	13,699.68	0.31	PARK	
B	37,018.42	0.85	37,018.42	0.85	PRIVATE STREET	
C	97,488.19	2.24	97,488.19	2.24	PRIVATE STREET	
D	17,789.53	0.41	17,789.53	0.41	PRIVATE STREET	
E	36,897.43	0.85	36,897.43	0.85	PRIVATE STREET	
F	32,110.37	0.74	32,110.37	0.74	WATER QUALITY	
G	87,364.82	2.01	87,364.82	2.01	OPEN SPACE	PASSIVE RECREATIONAL PARK OPEN SPACE
H	19,798.48	0.45	19,798.48	0.45	OPEN SPACE	SLOPE OPEN SPACE
J	5,005.10	0.11	5,005.10	0.11	WATER QUALITY	
K	38,685.71	0.89	38,685.71	0.89	WATER QUALITY	
L	28,458.07	0.65	28,458.07	0.65	WATER QUALITY	
N	18,423.90	0.42	18,423.90	0.42	OPEN SPACE	SLOPE OPEN SPACE
P	89,273.76	2.05	89,273.76	2.05	OPEN SPACE	SDG&E EASEMENT & FIRE BUFFER OPEN SPACE
Q	82,517.05	1.89	82,517.05	1.89	OPEN SPACE	SDG&E EASEMENT & FIRE BUFFER OPEN SPACE
R	167,599.45	3.85	167,599.45	3.85	OPEN SPACE	FIRE BUFFER OPEN SPACE
S	2,314,336.49	53.13	2,314,336.49	53.13	OPEN SPACE	BIOLOGICAL OPEN SPACE W/ EXCEPTION OF THE SDGE EASEMENT
T	12,550.26	0.29	12,550.26	0.29	OPEN SPACE	SLOPE OPEN SPACE
TOTAL	3,886,917.99	89.23	3,886,917.99	89.23		

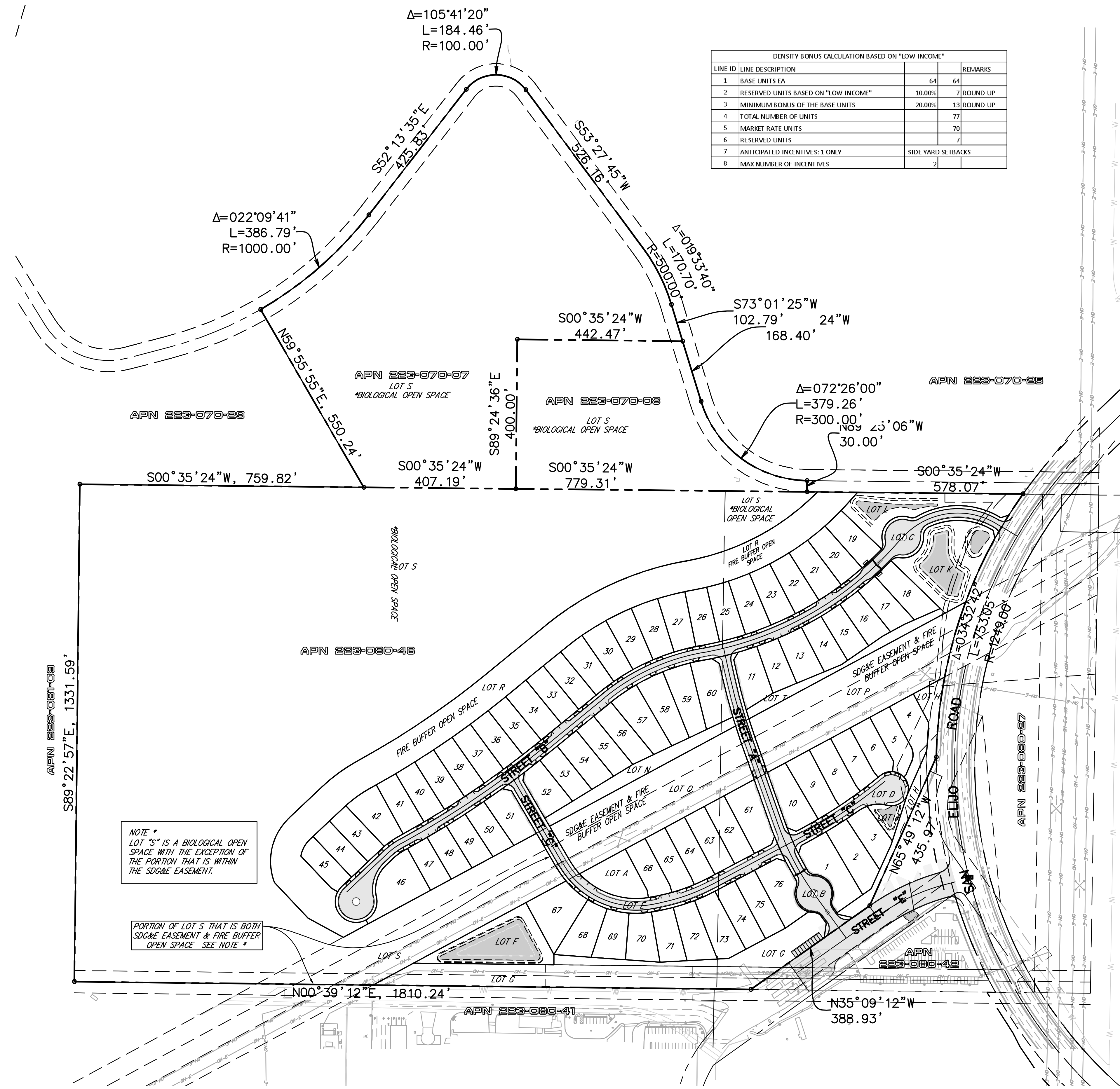

NOTE *
LOT "S" IS A BIOLOGICAL OPEN SPACE WITH THE EXCEPTION OF THE PORTION THAT IS WITHIN THE SDG&E EASEMENT.

PORTION OF LOT S THAT IS BOTH SDG&E EASEMENT & FIRE BUFFER OPEN SPACE - SEE NOTE *

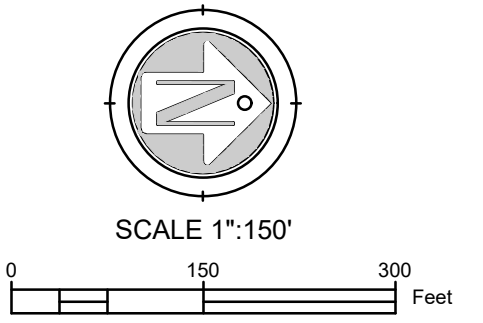

APN 223-080-27

SEE GENERAL NOTE 15
ON SHEET 1
APN 223-080-42

APN 223-070-25

APN 223-080-41

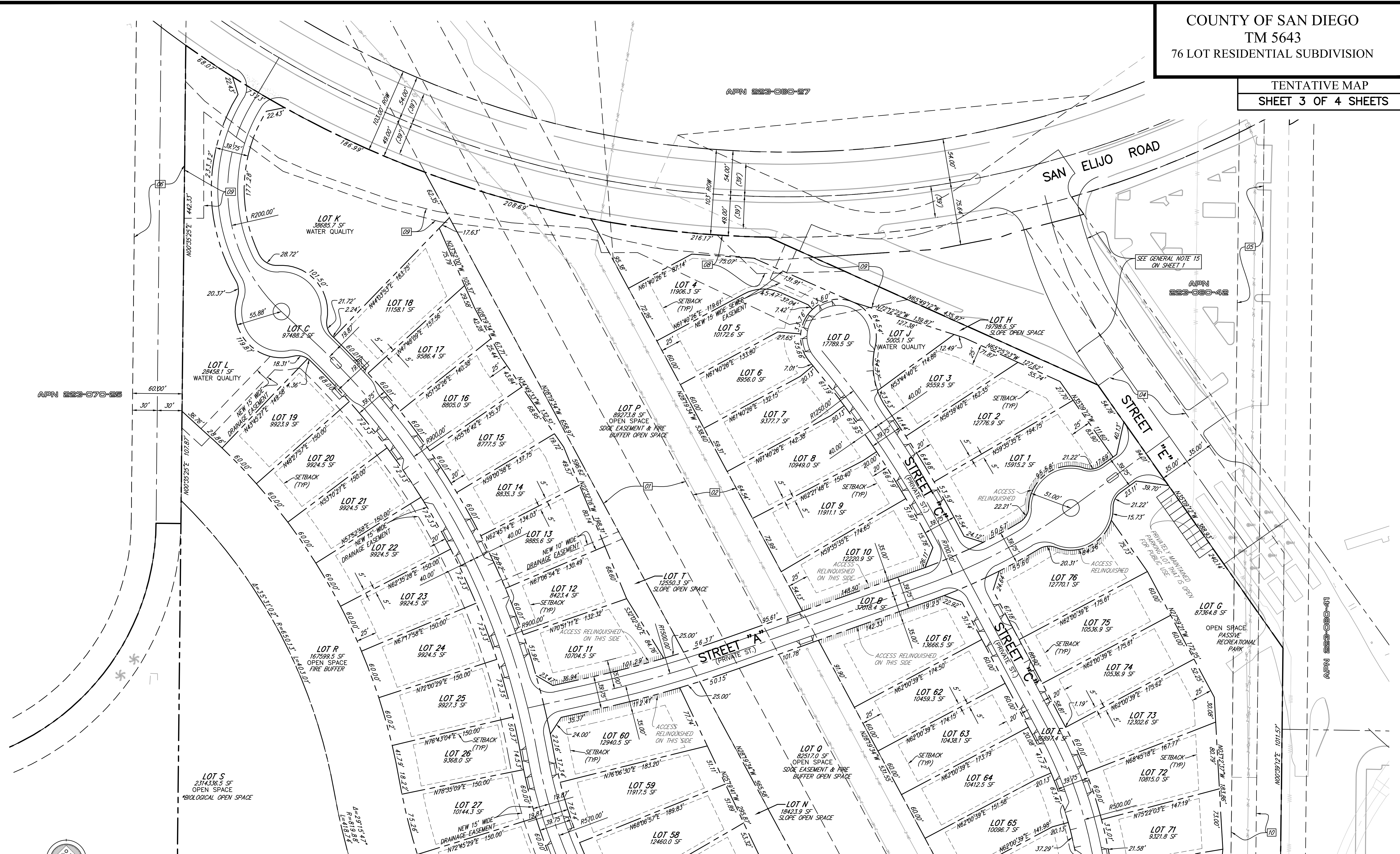

MATCHLINE SEE SHEET 4 FOR CONTINUATION

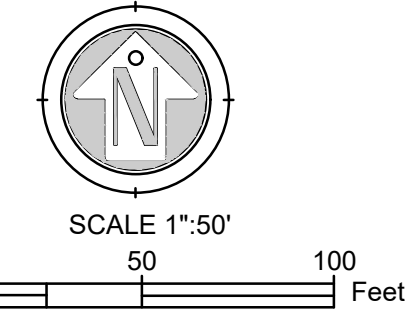

K:\19\190208\Engineering\TM\TM04\1m\190208 TM.dwg 2/21/2024 4:11 PM ORIGINAL PLOT SIZE: -----

MATCHLINE SEE SHEET 3 FOR CONTINUATION

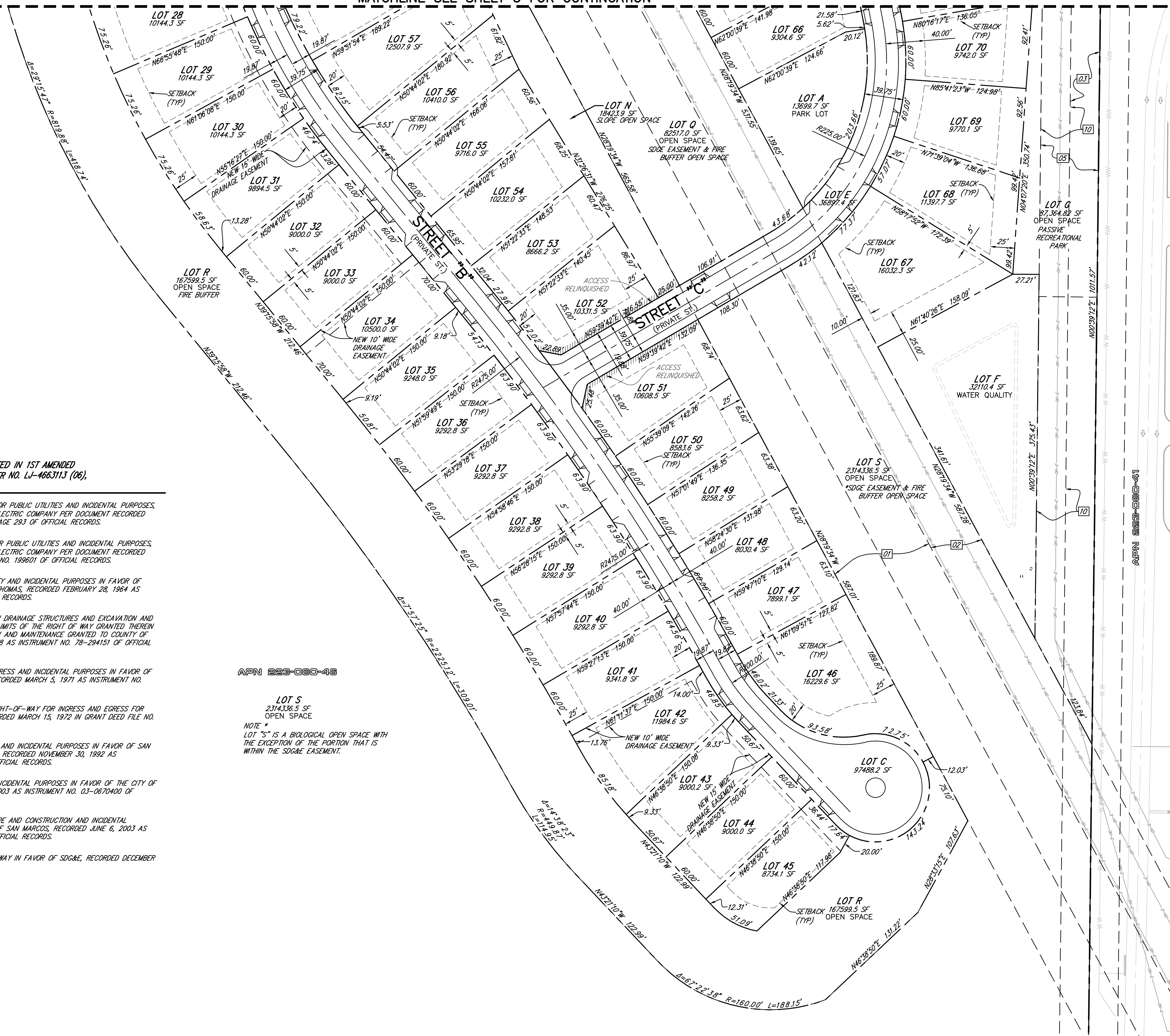

EXISTING EASEMENTS AS NOTED IN 1ST AMENDED
 PRELIMINARY TITLE REPORT ORDER NO. LJ-4663113 (06),
 UPDATED 10/14/2016

- [01] AN EXISTING 100' WIDE EASEMENT FOR PUBLIC UTILITIES AND INCIDENTAL PURPOSES, GRANTED TO SAN DIEGO GAS AND ELECTRIC COMPANY PER DOCUMENT RECORDED OCTOBER 11, 1940 IN BOOK 1082, PAGE 293 OF OFFICIAL RECORDS.
- [02] AN EXISTING 50' WIDE EASEMENT FOR PUBLIC UTILITIES AND INCIDENTAL PURPOSES, GRANTED TO SAN DIEGO GAS AND ELECTRIC COMPANY PER DOCUMENT RECORDED NOVEMBER 3, 1965 AS INSTRUMENT NO. 199601 OF OFFICIAL RECORDS.
- [03] AN EASEMENT FOR ROAD AND UTILITY AND INCIDENTAL PURPOSES IN FAVOR OF JOHN A. THOMAS, JR AND AVIS C. THOMAS, RECORDED FEBRUARY 28, 1964 AS INSTRUMENT NO. 37644 OF OFFICIAL RECORDS.
- [04] THE RIGHT TO EXTEND AND MAINTAIN DRAINAGE STRUCTURES AND EXCAVATION AND EMBANKMENT SLOPES BEYOND THE LIMITS OF THE RIGHT OF WAY GRANTED THEREIN WHERE REQUIRED FOR CONSTRUCTION AND MAINTENANCE GRANTED TO COUNTY OF SAN DIEGO, RECORDED JULY 14, 1978 AS INSTRUMENT NO. 78-294151 OF OFFICIAL RECORDS.
- [05] AN EASEMENT FOR INGRESS AND EGRESS AND INCIDENTAL PURPOSES IN FAVOR OF NORAD DEVELOPMENT COMPANY, RECORDED MARCH 5, 1971 AS INSTRUMENT NO. 41512 OF OFFICIAL RECORDS.
- [06] A 60 FOOT WIDE EASEMENT AND RIGHT-OF-WAY FOR INGRESS AND EGRESS FOR ROAD AND UTILITY PURPOSES, RECORDED MARCH 15, 1972 IN GRANT DEED FILE NO. 61527 OF OFFICIAL RECORDS.
- [07] AN EASEMENT FOR PUBLIC UTILITIES AND INCIDENTAL PURPOSES IN FAVOR OF SAN DIEGO GAS AND ELECTRIC COMPANY, RECORDED NOVEMBER 30, 1992 AS INSTRUMENT NO. 92-0764106 OF OFFICIAL RECORDS.
- [08] AN EASEMENT FOR DRAINAGE AND INCIDENTAL PURPOSES IN FAVOR OF THE CITY OF SAN MARCOS, RECORDED JUNE 6, 2003 AS INSTRUMENT NO. 03-0670400 OF OFFICIAL RECORDS.
- [09] AN EASEMENT FOR TEMPORARY SLOPE AND CONSTRUCTION AND INCIDENTAL PURPOSES IN FAVOR OF THE CITY OF SAN MARCOS, RECORDED JUNE 6, 2003 AS INSTRUMENT NO. 03-0670401 OF OFFICIAL RECORDS.
- [10] A 30' WIDE EASEMENT & RIGHT OF WAY IN FAVOR OF SD&E, RECORDED DECEMBER 24, 1992.

APN 223-080-46

LOT S
 2314.336.5 SF
 OPEN SPACE
 NOTE *
 LOT "S" IS A BIOLOGICAL OPEN SPACE WITH
 THE EXCEPTION OF THE PORTION THAT IS
 WITHIN THE SD&E EASEMENT.

