

COUNTY OF SAN DIEGO TRACT TM
 PRELIMINARY GRADING PLAN
 NEWLAND SIERRA

SEE BELOW: RIGHT

SEE SHEET 13

SEE SHEET 13

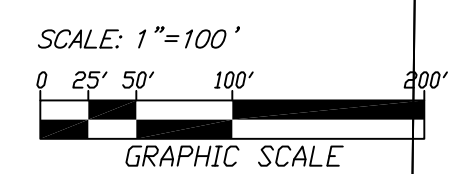
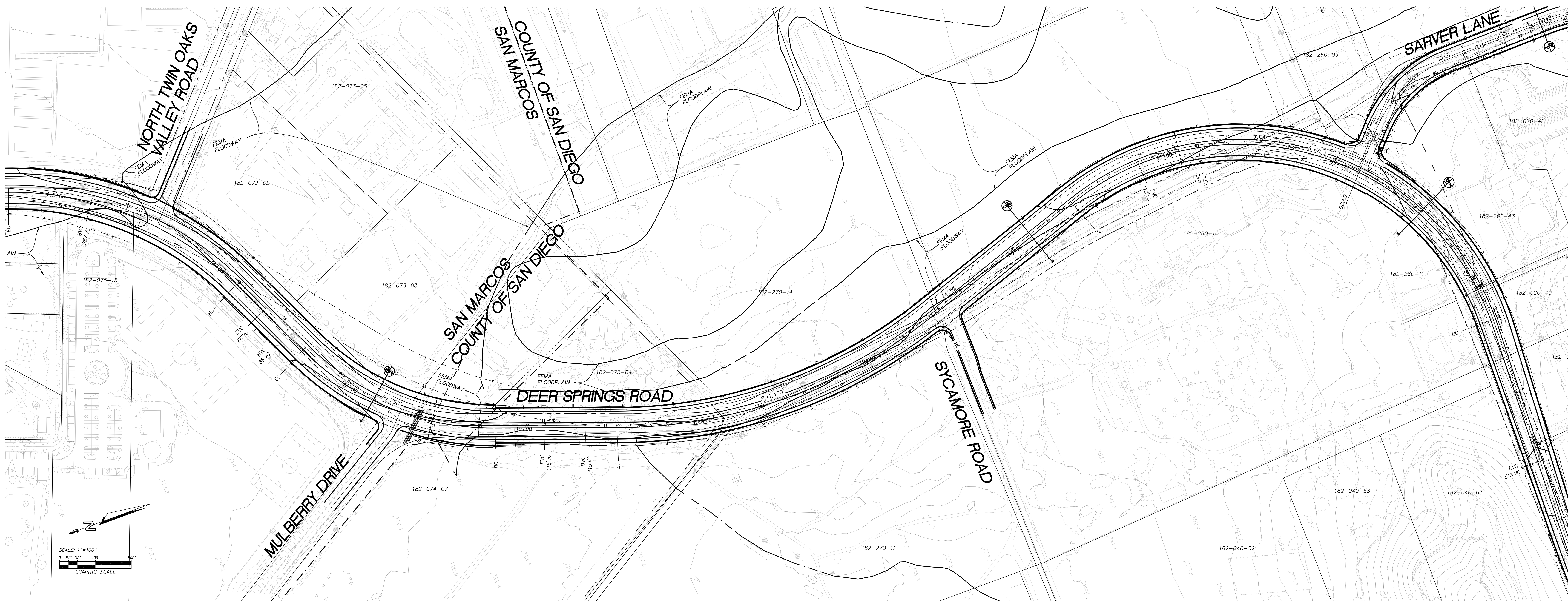

SEE ABOVE: LEFT

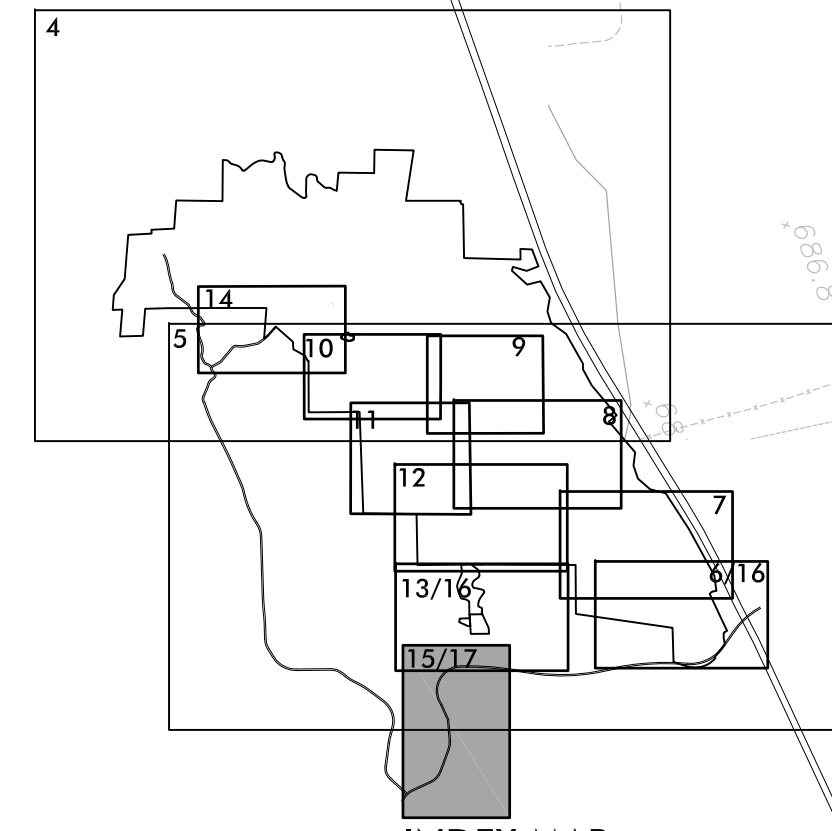
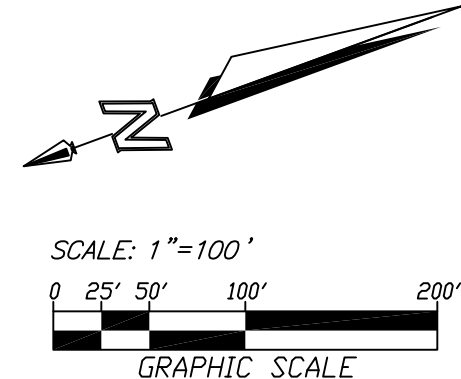

DEER SPRINGS ROAD ALTERNATE A
 SEE SHEET 17 FOR ALTERNATE B

ENGINEER OF WORK
 FUSCOE ENGINEERING
 6390 GREENWICH DRIVE, STE. 170
 SAN DIEGO, CA 92122
 (619) 554-1500

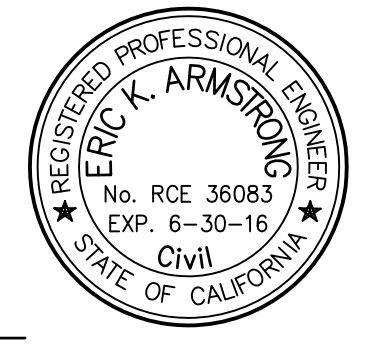

ERIC K. ARMSTRONG RCE 36083 DATE

SHEET 15 OF 17

NO.	DATE	REVISION

