

COUNTY OF SAN DIEGO TRACT TM  
TENTATIVE MAP  
NEWLAND SIERRA

NET LOT AREAS			
LOT	SQUARE FEET	ACRES	COMMENTS
1	39,382	0.90	
2	40,245	0.92	
3	26,765	0.61	
4	36,472	0.84	
5	50,195	1.15	
6	29,036	0.67	
7	58,524	1.34	
8	28,714	0.66	
9	28,042	0.64	
10	70,656	1.62	FOR 14 CONDOMINIUMS
11	106,502	2.44	FOR 32 CONDOMINIUMS
12	87,649	2.01	FOR 35 CONDOMINIUMS
13	67,478	1.55	FOR 14 CONDOMINIUMS
14	160,225	3.68	
OS-1	1,144,848	26.28	OPEN SPACE
OS-2	2,528	0.06	OPEN SPACE
P-1	87,762	2.01	PARK
P-2	37,747	0.87	PARK
P-3	123,551	2.84	PARK

LINE TABLE		
NO.	BEARING	DISTANCE
L1	N32°06'08"E	11.69'
L2	N49°45'22"W	30.00'
L3	N37°51'48"E	40.40'
L4	N10°18'49"E	62.66'
L5	N17°00'00"W	30.00'
L6	N64°40'22"E	60.01'
L7	N43°30'03"E	48.96'

CURVE TABLE			
NO.	DELTA	RADIUS	LENGTH
C1	23°20'49"	492.04'	200.50'
C2	58°19'33"	60.01'	61.08'
C3	36°21'58"	89.78'	56.98'
C4	3°49'58"	1425.50'	95.36'

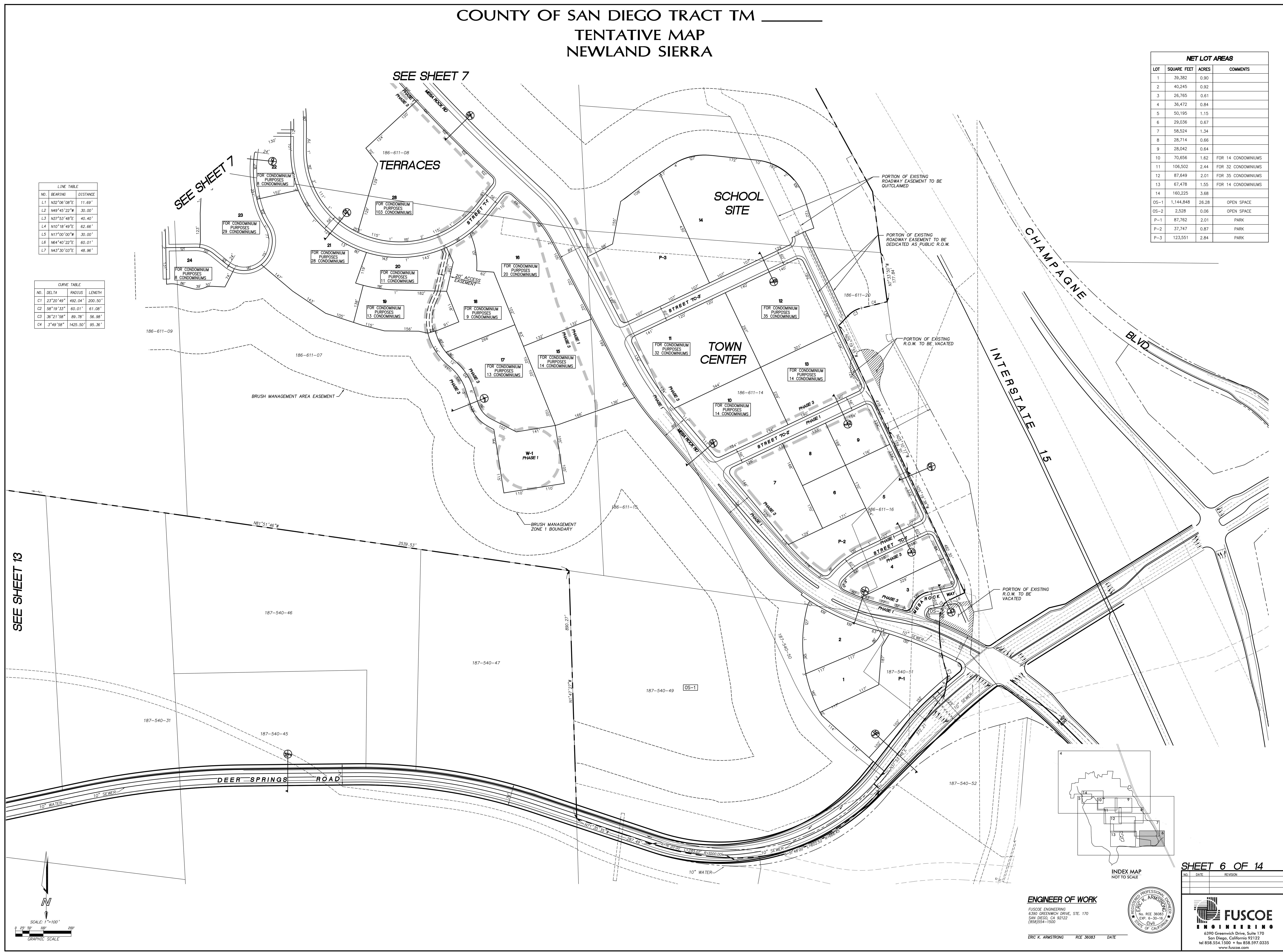

SEE SHEET 13

SEE SHEET 7

SEE SHEET 7

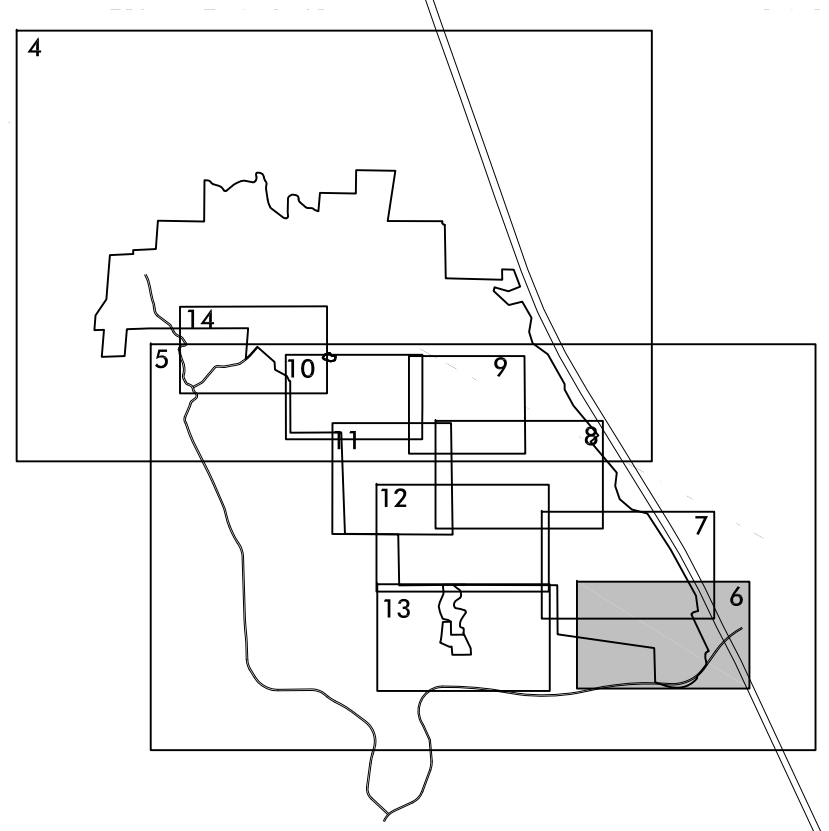

SHEET 6 OF 14

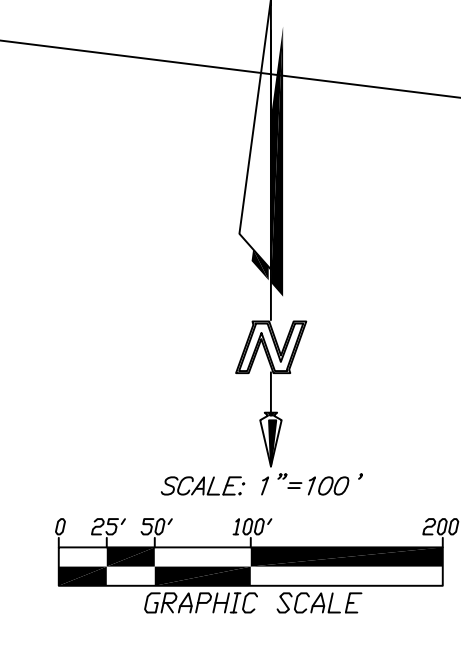

**ENGINEER OF WORK**  
FUSCOE ENGINEERING  
6390 GREENWICH DRIVE, STE. 170  
SAN DIEGO, CA 92122  
(619)554-1500

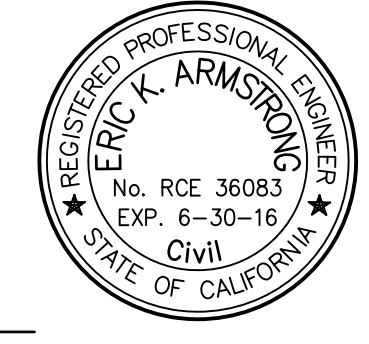

**FUSCOE ENGINEERING**  
6390 Greenwich Drive, Suite 170  
San Diego, California 92122  
Tel 858-554-1500 • fax 858-597-0335  
www.fuscoe.com

NO.	DATE	REVISION

ERIC K. ARMSTRONG RCE 36082 DATE